



Pre-Paint>Fuselage>Firewall>Fit engine mount and engine

Issue Revision Table

Issue	Date:	Change(s):	Issued by:
1			
2			
3	6/07/2021	Adopt "Section Only" Manual System, Add Issue Revision Table and model applicability.	AS

Model Applicability

Aircraft Model	J-160	J-170	J-230	J-430
Document Applicability			Yes	Yes

This document is controlled while it remains on the Jabiru server. Once this no longer applies it becomes uncontrolled.

Issue:	0	1	2	3						Issued by: AS	Page: 1 of 7 11 November 2021
--------	---	---	---	---	--	--	--	--	--	---------------	-------------------------------

Pre-Paint>Fuselage>Firewall>Fit engine mount and engine

Objectives of this task:

In this task the engine mount will be fitted to the firewall at the top attach points only, the engine will be attached to the engine mount, then the engine angle of incidence will be set and finally the engine mount will be fitted to the bottom attach points on the firewall.

The engine angle of incidence is particularly important, both to the general flying qualities of the aircraft as well as making the fitting of the cowls more straightforward, and should be set carefully and precisely. You will need either a portable engine lifter or a few strong friends to help you mount and position the engine in this task.

From this point on the engine will remain fitted to the fuselage.

Parts required:

Engine mount sets: Mount rubbers, spacers, rubber mounts ▶

From Card # 10J 'Firewall', the 4 x 4025094 backing plates (photo below right)

Hardware pack: AN4-20A & -31A bolts plus nuts and washers.



Fit the engine mount to the firewall

Now would be a very good time to paint the engine mount! We prefer gloss black.

Drill the top engine mounting holes through the stainless steel firewall plate from the inside, through the pre-drilled holes in the plywood firewall that you cleaned in the previous task.



Attach the engine mount to the firewall with the top (AN4-20A) bolts only: fit each bolt from the front, through the mount, firewall, and the backing plate (shown at right) and fit a washer and Nyloc nut. Tighten the Nyloc nut firmly but without crushing the plywood firewall. Do not bolt the bottom of the engine mount to the firewall at this stage; leave it until the engine angle of incidence has been set.



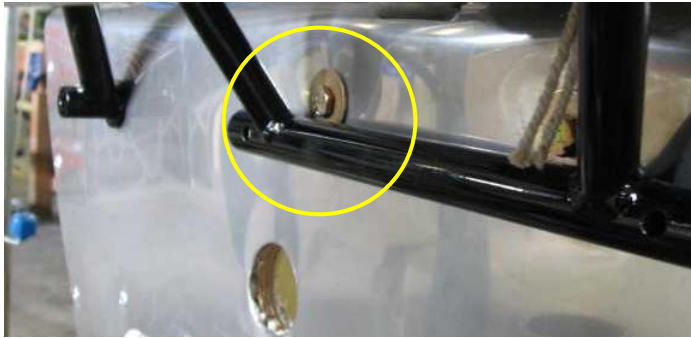

Note that the bottom centre section of the engine mount (shown at left) rests *against* the penny washers of the top internal brace bolts but does **not** rest on the heads of the bolts.

Fit the engine to the engine mount

Fit the female rubbers to the top mounts and the machined spacers and male rubbers to the bottom mounts – refer to the drawing on the next page for details.

With the rear of the aircraft supported and with the main wheels chocked, lift the engine into position and fit the rear engine mount plate onto the bottom engine mounts first: you may need to tilt the engine slightly down at the front to do this. Use AN4-31A bolts fed from the rear of the mounts with the lock nuts towards the front.

Lift the front of the engine and fit the top rear engine mount plate onto the top mounts and fit the male rubbers, machined washers, flat washers and lock nuts to both top mounts. Fit the female rubbers, flat washers and lock nuts to both bottom mounts. Note that these are *steel* lock nuts and not Nylocs.

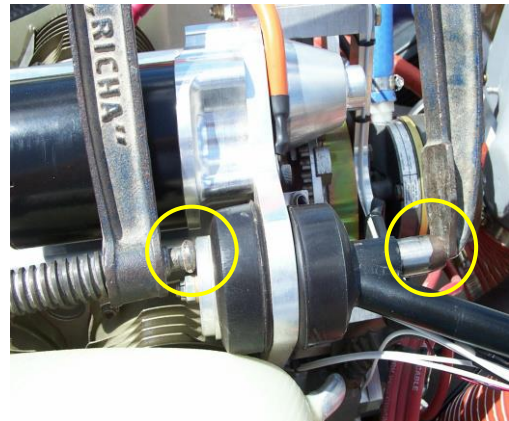

It may be necessary to compress the mount rubbers in order to get the steel lock nuts on: use a “G” clamp or similar and clamp across a socket on the head of the bolt and the side of the machined washer beside the steel lock nut, as shown at right. The clamping points have been circled in yellow.

Torque each of the 4 steel lock nuts to 11 Nm (8 foot pounds).

Level the aircraft

For the next step the aircraft must be absolutely level in both the lateral (rolling) and longitudinal (pitching) planes.



Lateral plane: place a 3” block on the top of each front wing mounting lug and place a spirit level or a digital protractor across the top of the cabin so that it rests on both blocks. Pack the main wheels as required to level the aircraft.

Longitudinal plane: the objective is to level the fuselage along the “waterline” – the line of the join between the upper and lower sections of the fuselage. Use a spirit level or a digital protractor and pack under the nose wheel or empennage until the waterline is level.

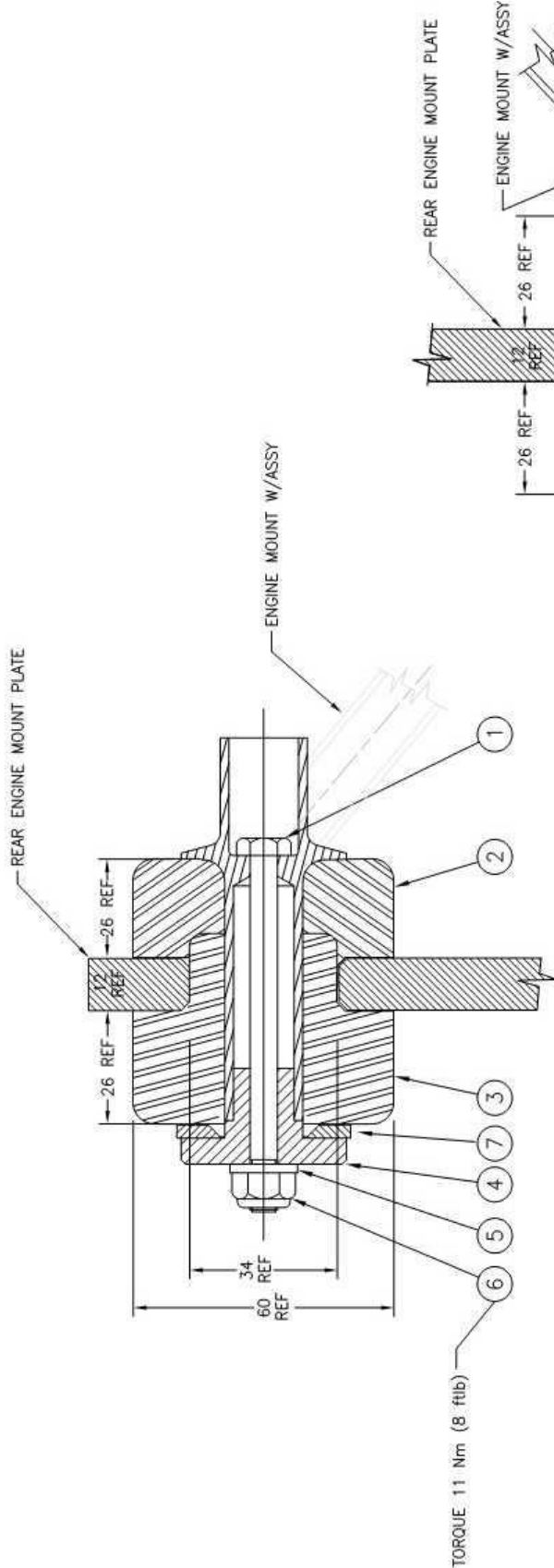

UPPER ENGINE MOUNT CONFIGURATION

APPLICABLE JABIRU 2200, AND 3300 ENGINE INSTALLATIONS IN JABIRU AIRCRAFT

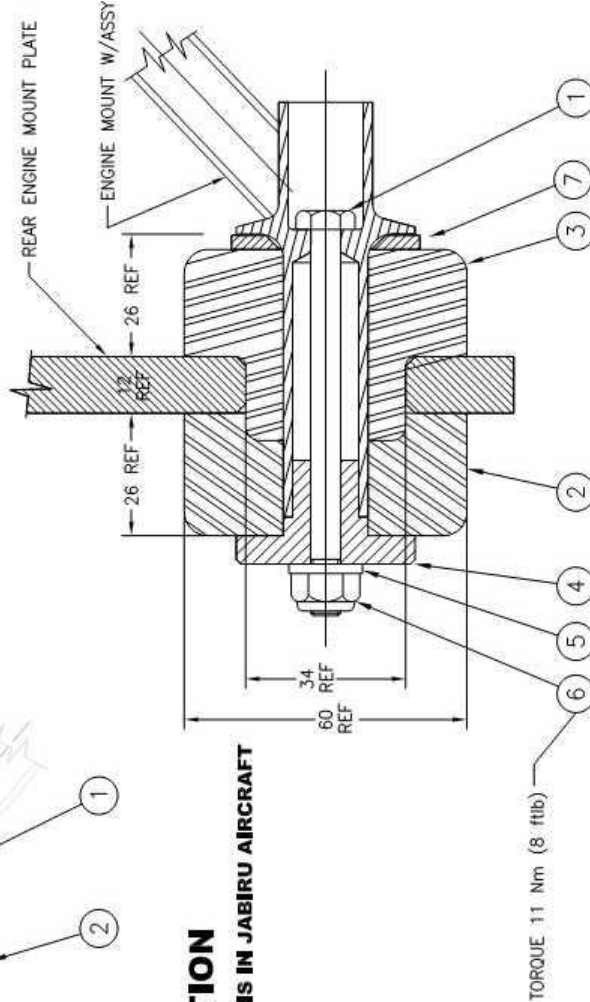

TORQUE 11 Nm (8 ftlb)

LOWER ENGINE MOUNT CONFIGURATION

APPLICABLE JABIRU 2200, AND 3300 ENGINE INSTALLATIONS IN JABIRU AIRCRAFT

ITEM	PART No.	DESCRIPTION	QTY.
7	4214934	WASHER- ENG MNT SPACER	1
6	MS21042-4	NUT	1
5	AN960-416	WASHER	1
4	4094224	WASHER ENGINE MOUNT	1
3	PG10722N	CUSHION MOUNT MALE	1
2	PG10712N	CUSHION MOUNT FEMALE	1
1	AN4-31A	BOLT	1

SCALE	2	010528
ISS.	1	001109
DATE		
DWG. NO.	9606004	
SHEET 1 OF 1	TA3	

AVTECH P/L A.C.N. 010 786 973 HINKLER AIRPORT BLUNDBERG	APK	
DRAWN	APK	
PURCHASED PARTS TO	PS22J-10	APPR.
TITLE VIBRATION MOUNT INSTALLATION		
JABIRU AIRCRAFT		

Set the engine angle of incidence

In this step the engine will be adjusted until a level or digital protractor (pictured below) placed on the top of the crankcase reads completely level fore and aft, which indicates an angle of incidence of 0° (zero degrees).

In our factory we usually find that the angle of incidence is correct with the standard mount, however the following procedure should still be followed.

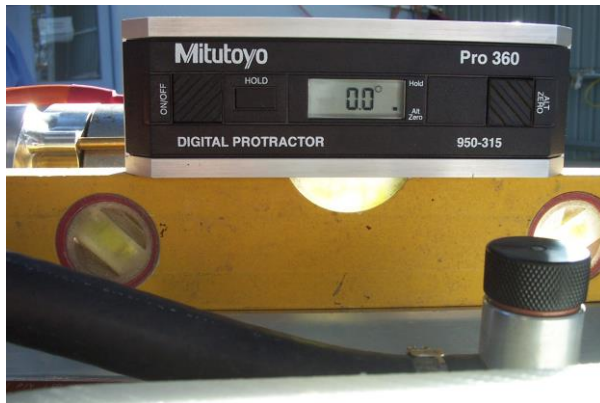

Recheck that the aircraft is completely level and then measure the angle of incidence and use a hydraulic jack under the crankcase to lift the front of the engine to a point where the engine has a very slight (0.5° if using a digital protractor) nose-up attitude then drill the bottom engine mount holes through the firewall and fit the AN4-20A bolts, backing plates, washers and Nyloc nuts. Now release the jack and recheck the angle of incidence. If the engine is slightly down at the front you can fit up to a maximum of 3 penny washers under each bottom engine mount to adjust the angle of incidence. Bear in mind that a small adjustment at the firewall will result in a large change at the propeller flange.

Check the lateral angle of the engine while the aircraft is completely level: it should be very close to level.

Once you're happy with the alignment you can permanently install the lower engine mount bolts, taking care to remember the backing plate (pictured on the first page of this task), and tightening the Nyloc nuts enough to hold firmly but without crushing the plywood firewall.

If penny washer spacers were used on the lower engine mounts then equivalent thickness spacers will need to be used behind the bottom bar on the mount. Drill these mounting holes at 3/16", fit the appropriate spacers if required, and finally fit 2 x AN3 bolts through the bottom bar and the firewall and fit washers and Nyloc nuts.

This completes the *Pre-Paint>Fuselage>Firewall forward>Fit engine mount and engine* task.