



Jabiru Construction Manual
Pre-Paint>Fuselage>Undercarriage>Assemble main gear

Pre-Paint>Fuselage>Undercarriage>Assemble main gear

Issue Revision Table

Issue	Date:	Change(s):	Issued by:
2	6/07/2021	Adopt "Section Only" Manual System, Add Issue Revision Table and model applicability. New pictures and drawings showing brake return springs	AS

Model Applicability

Aircraft Model	J-160	J-170	J-230	J-430
Document Applicability	Yes	Yes	Yes	Yes

This document is controlled while it remains on the Jabiru server. Once this no longer applies it becomes uncontrolled.

Issue:	0	1	2							Issued by: AS	Page: 1 of 7 15 October 2021
--------	---	---	---	--	--	--	--	--	--	---------------	------------------------------

Pre-Paint>Fuselage>Undercarriage>Assemble main gear>Procedure

Objectives of this task:

In this task you will assemble the main undercarriage legs, which includes fitting the axles, disc brakes and wheels.

Materials required:

- Cards # 29JT ‘Brakes MK3’ and 28JT ‘Main wheels MK3’
- Rubber grease for assembly of disc brake pistons

Assemble spat brackets

Fit the retained nuts to the spat mounting brackets using countersunk 3/32” rivets. There are 4 retained nuts (arrowed) on each bracket. Countersink the actual screw holes where the spat will be fitted: the countersinks will help to guide the screws into the holes when fitting the spats.

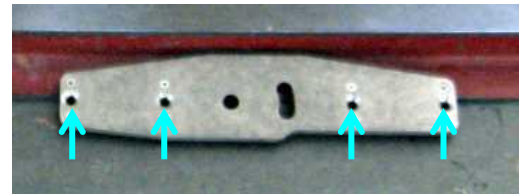

Fit the stub axles, backing plates and Spat brackets

Slide the stub axle washer over the stub axle, then place four bolts with thin washers (AN960-516L) though the corresponding holes on the stub axle, the mounting plate and finally the undercarriage gear leg. The two longer bolts (AN5-24A) must be positioned through the top two holes, whilst the shorter bolts (AN5-21A) reside in the bottom two holes. Ensure that the hole on the outboard end of the stub axle (indicated by a green arrow) is aligned vertically.

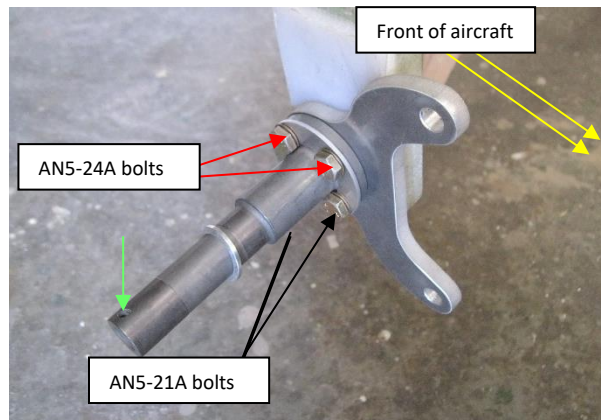

Place the spacer plate on the back over the two longer bolts followed by the newly assembled spat bracket. The capture nuts on the spat bracket must face outboard (towards the stub axle). The hole in the spat bracket is placed over the front bolt, while the curved slot resides over the rear bolt.

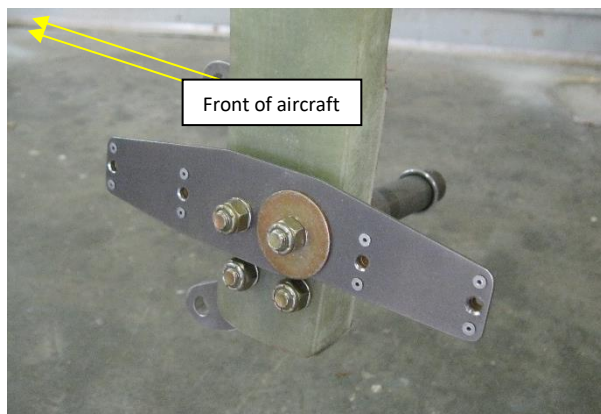

Fix the assembly in place with washers and nyloc nuts. A penny washer is used to cover the slot on the spat bracket. The purpose of the slot is to allow adjustment when it comes time to fit the wheel spat.

At this stage it is of benefit to mark the legs as left or right with a permanent marker pen. This may save confusion during the fitting of the main undercarriage gear. One should also note that at this

stage the axles will likely not be correctly aligned on the undercarriage legs. This issue is dealt with in a later section ([Pre-Paint>Fuselage>Wheel alignment](#)).

Assemble the brake calipers

In this step you will assemble the hydraulic disc brake calipers. Cleanliness is essential when working with hydraulic brake parts, so clean your working area and your hands thoroughly before starting this step.



Use compressed air to clean any dust and dirt from the inside of the brake calipers and pistons. Apply rubber grease to the O-rings and fit one to each piston, then apply a smear of rubber grease to the inside of the caliper and fit both pistons into each caliper: press the pistons gently into the caliper with the cupped side of the pistons facing outwards.

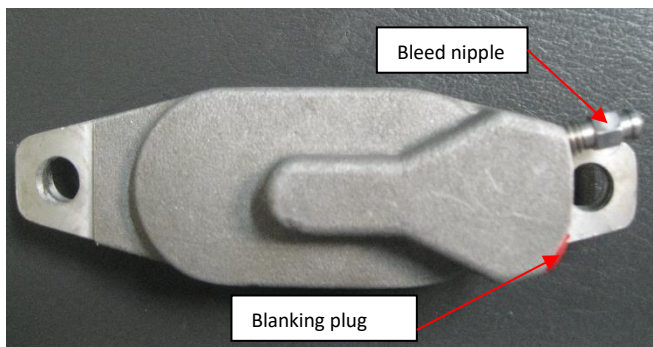

Thread and tighten a bleed nipple into the appropriate fitting on the caliper and push a blanking plug the other fitting as shown at left – the brake lines will be fitted later in *Post-Paint* and the blanking plug will keep the caliper sealed until then.

Wash any grease off your hands with soap and water – it can irritate sensitive skin.

Refer to the drawing on the next page for an

overview of the brake system.



ITEM	PART No.	DESCRIPTION	QTY
1	8A058C0D-1	MACHINED DUAL PISTON HOUSING RS MK3	1
2	8A055G0D-1	PERFORMANCE BRAKE PISTON	2
3	6100094-4	NIPPLE BRAKE BLEEDER	1
4	6207324-1	1.25" BRAKE CYLINDER FITTING	1
5	8A058E8D-1	LOCK TAB MK3 BRAKE	2
6	PD0082N	3/16" FERRULE (NYLON BRAKE LINE)	1
7	8A058E1D-2	CALIPER MOUNT PLATE MK3 BRAKE	1
8	8A058E2D-1	SLEEVE CALIPER MOUNT MK3 BRAKE	2
9	8A058E3D-1	INNER BRAKE PAD ASSY MK3 BRAKE	1
10	8A058E5D-1	OUTER BRAKE PAD ASSY MK3 BRAKE	1
11	PG4A002N-1	RV0214 O-RING	2
12	AN4-15A	1/4" BOLT	2
13	AN960-416L	1/4" THIN FLAT WASHER	2
15	PX4A003N-1	MK3 BRAKE CALIPER RETURN SPRING	2

DM	4	4/9/18
AS	3	28/01/14
JW	2	05/12/11
ISS.	1	26/07/2011
DATE		

ISS 4: RETURN SPRINGS ADDED
ISS 3: ASSEMBLE IN CORRECT DIRECTION

SECTION B-B

PROJECTION GENERAL TOLERANCES WHOLE NO.'S ± 0.5 ONE DEC. ± 0.25 TWO DEC. ± 0.05 ANGLES ± 0.5 MATERIAL	DIMENSIONS IN MILLIMETRES	DO NOT SCALE DRAWN APPR.	AVTECH P/L A.C.N. 010 786 973 HINKLER AIRPORT BUNDBERG 4670
THIS DRAWING IS COPYRIGHT AND MUST NOT BE COPIED WITHOUT THE CONSENT OF AVTECH PTY LTD		SCALE 1:2	TITLE BRAKE CALIPER ASSY RS MK3
		DWG. No. 6A059E0D-4	SHEET 2 OF 2 A4

Assemble the brake and wheel

First place the brake caliper on the inboard side of the mount plate and slide both caliper sleeves through the holes in the mount plate and caliper. The bleed and brake-line fittings on the caliper should face upwards. Ensure that you fit the correct caliper, since the left and right parts are different. The picture on the right identifies them.

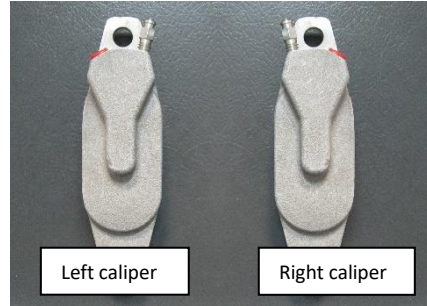

Now you can place the inboard brake pad over the caliper sleeves. Slide AN4-15A bolts into each sleeve with lock tabs under each bolt head, **insert brake returns springs over the caliper sleeves**, place thin 1/4" plain washers (AN960-416L) on the end of each bolt. Thread the outer brake pad onto the bottom bolt and leave it hanging down as pictured below on the right.

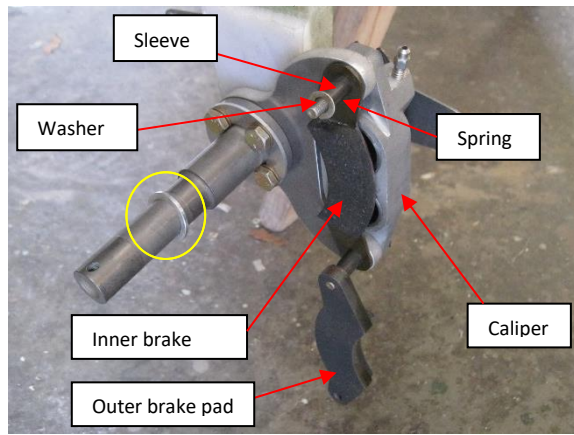
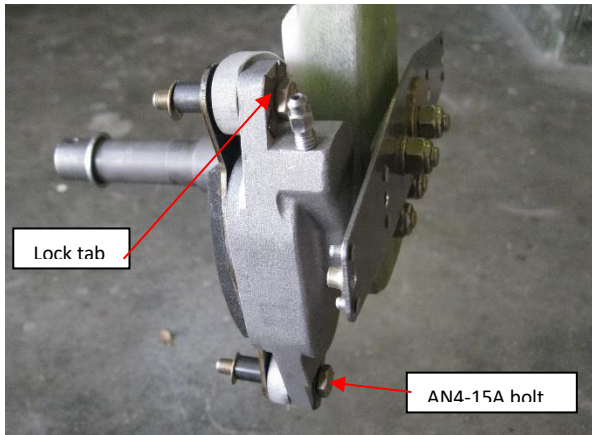

Before installing the wheels, slide the stub axle spacer (circled in yellow above) onto the shaft, the flat face should be facing outboard to provide the wheel bearings with a nice square face to sit against. Now you can slide the wheel onto the stub axle. Slide it on all the way until the brake disc rests against the inner brake pad. Secure the wheel with the axle extension, fitting the AN3-12A bolt from the top with a washer and nyloc nut at the bottom.

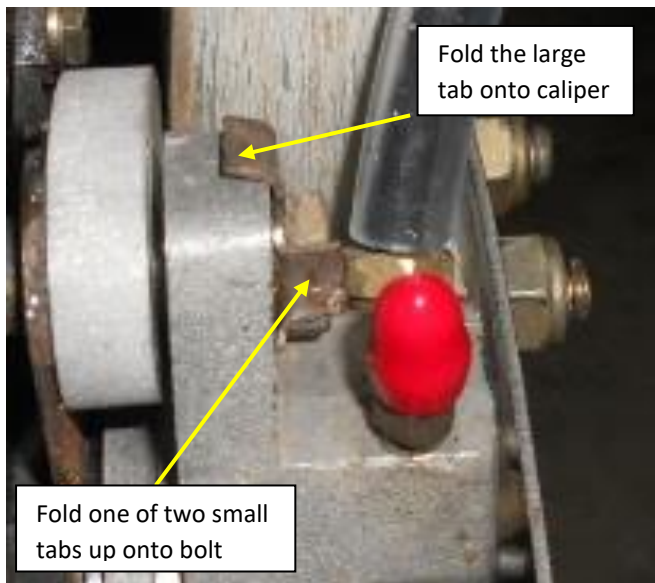

Now swing the outer brake pad around and thread the top bolt into it. Tighten both bolts. Check that the wheel and disk runs smoothly and is not impeded by the brake pads. The distance between the disk and outer pad should be about 1 millimetre.

The picture to the left shows the completed brake assembly of the right hand undercarriage gear. The last step is to fold one of the small lock tab leaves up against the bolt head and the large tab onto the machined caliper housing. It is useful to refer to the drawings on the following pages during main undercarriage gear assembly.



ITEM	PART NO.	DESCRIPTION	QTY
1	5204023	MAIN UNDERCARRIAGE LEG	1
2	6A02880D	SERIES II STUB AXLE	1
3	6A02800D	SERIES II STUB AXLE SPACER	1
4	6A06040D	BARE MAIN WHEEL ASSY TO SUIT MARK 3 BRAKE	1
5	6A05980D	BRAKE CALIPER ASSY RS MK3	1
6	AN60-516	WASHER	4
7	MS20365-524	5/16" NYLOC NUT	4
8	6A05930D	WASHER STUB AXLE MOUNTING	1
9	6A05400D	SPACER BRACKET	1
10	AN5-21A	AN5-21A BOLT	2
11	AN5-24A	AN5-24A BOLT	2
12	AN60-516L	HALF WASHER	4
13	6000594-9	EXTENSION - STUB AXLE +207mm	1
14	AN3-12A	3/16" BOLT	1
15	AN60-10	3/16" FLAT WASHER	1
16	MS20365-1032	3/16" NYLOC NUT	1

ISS 5: UPDATED PARTS & ADDED STUB AXLE EXTENSION
ISS 4: INCLUDE SPACER BRACKET

DM	5	48/18
AS	4	28/01/14
JW	3	19/07/13
JW	2	
JW	2	

SCALE	1:2
ISS.	1
DATE	5/02/2011
DWG. No.	6A05940D-5
TITLE	BRAKE ASSY RS MK3

AVTECH P/L A.C.N. 010 786 973 HINKLER AIRPORT BUNDABERG 4670	DO NOT SCALE DRAWN JW	DIMENSIONS IN MILLIMETRES GENERAL TOLERANCES UNLESS OTHERWISE SPECIFIED ONE DEC. ± 0.25 TWO DEC. ± 0.10 ANGLES ± 0.5	THIS DRAWING IS COPYRIGHT AND MUST NOT BE COPIED WITHOUT THE CONSENT OF AVTECH P/L LTD
AS DETAILED	APPR.		

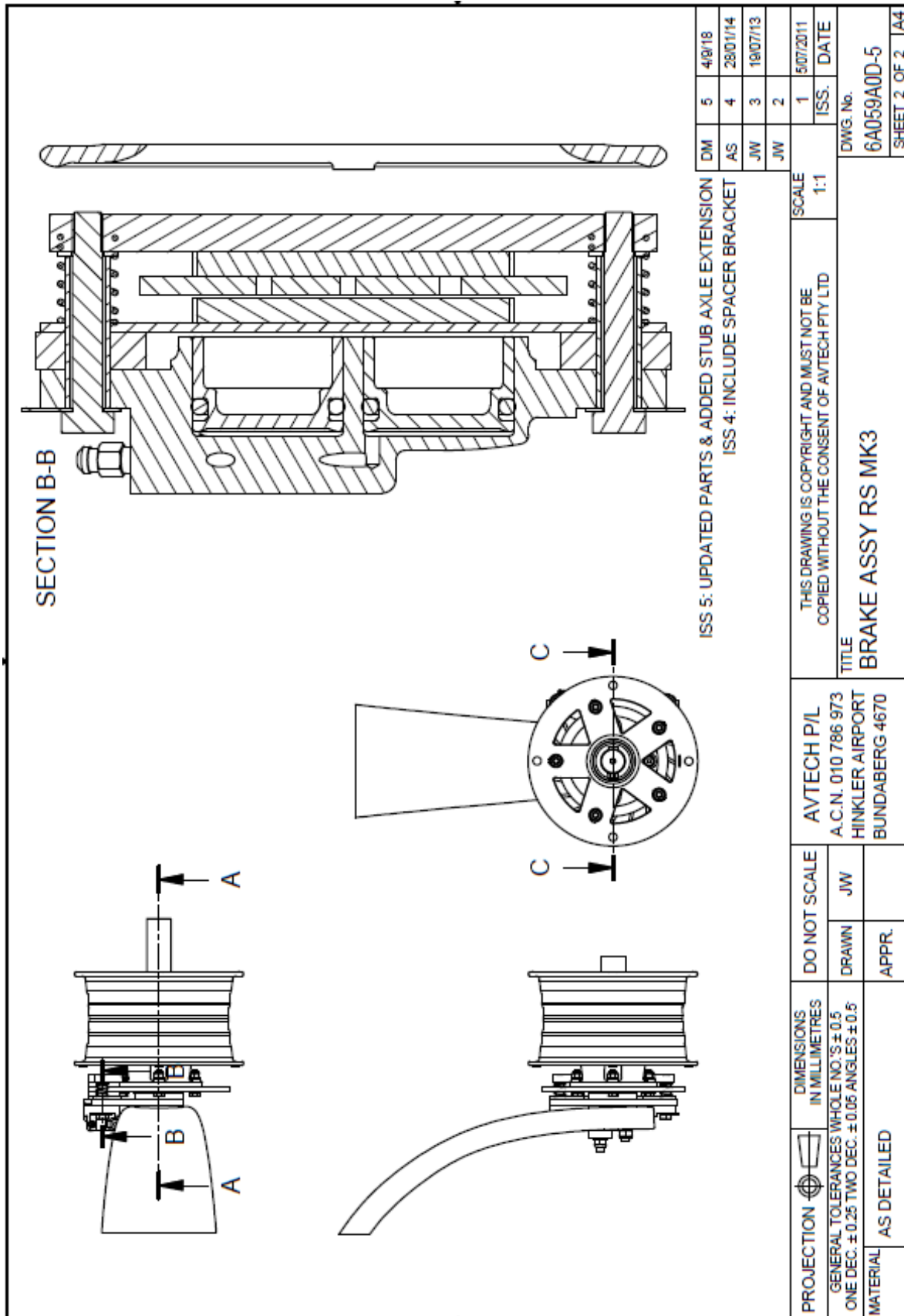

This completes the *Pre-Paint>Fuselage>Undercarriage>Assemble main gear* task.

This document is controlled while it remains on the Jabiru server. Once this no longer applies it becomes uncontrolled.										
Issue:	0	1	2					Issued by: AS	Page: 7 of 7	15 October 2021