

Jabiru Service Bulletin: Piston Circlips			JABIRU AIRCRAFT PTY LTD P.O. Box 5186 Bundaberg West Queensland, Australia. Phone: +61 7 4155 1778 Fax: +61 7 4155 2669 Email: info@jabiru.net.au		
JSB 033-	Release Date: 28th April 2014	Effective Date: 28th April 2014	Affected Models: See Applicability	S/No. Range: See Applicability	Page 1 of 5

SERVICE BULLETIN: JSB 033-2

Issue: 2

Subject: Piston Circlips

Release Date: 28th April 2014

Effective Date: 28th April 2014

Affected Models: Jabiru 2200 and 3300 Engines

Affected S/No: 22A-3554 to 22A-3564,
22A-3592MP511 – 22A-3595MP511
22A-3608MP511 – 22A-3611MP511
22A-1267, 22B-038, 22B-055, 22B-227, 22B-101, 22B-192,
22B-195, 22B-211. 22J-080
33A-2466 to 33A-2474. 33A-2480 to 33A-2483. 33A-2476,
33A-2486 to 33A-2493. 33A-2477, 33A-2498,
33A-2539, 33A-1417, 33A-1482, 33A-1860, 33A-1960,
33A-2024, 33A-2155, 33A-1114, 33A-1258, 33A-550, 33A-740,
Piston Kit T4A543A0D, Invoice date 10-Oct-11 to 28-Jun-12

Issue	Reason for Issue	Issue Status
1	Original Issue	Superseded.
2	Updated for piston replacement.	CURRENT

1 Table of Contents

1	TABLE OF CONTENTS	1
2	GENERAL	2
3	REQUIREMENTS:	2
3.1	ENGINES IN SERVICE	2
3.2	ENGINES IN STORAGE	2
4	COMPLIANCE – IMPLEMENTATION SCHEDULE:	3
4.1	ENGINES IN SERVICE:	3
4.2	ENGINES IN STORAGE:	3
5	PROCEDURE	4
5.1	GENERAL	4
5.2	NOTES	4

Jabiru Service Bulletin: Piston Circlips			JABIRU AIRCRAFT PTY LTD P.O. Box 5186 Bundaberg West Queensland, Australia. Phone: +61 7 4155 1778 Fax: +61 7 4155 2669 Email: info@jabiru.net.au		
JSB 033-	Release Date: 28th April 2014	Effective Date: 28th April 2014	Affected Models: See Applicability	S/No. Range: See Applicability	Page 2 of 5

General

- Jabiru Engines use circlips fitted to the piston to restrain the gudgeon pin (otherwise known as the “wrist pin”).
- In 2012 a batch of clips of 23mm diameter were supplied in some engines and as spare parts.
- A previous issue of this service bulletin, JSB033-1, covers 23mm made to JIS B 2804.
- The coverage of this service bulletin has been enlarged to cover all 23mm circlips.
- In some cases 23mm clips have dislodged in service leading to heavy engine damage.
- This bulletin details inspection and repair requirements to correct this condition.
- This bulletin is applicable to the Jabiru 2200 and 3300 engines listed on Page 1.
- This bulletin is equivalent to a Manufacturer’s Safety Direction.
- This bulletin has not been mandated (as an AD or similar) by any National Airworthiness Authority at the time of writing.

2 Requirements:

- 23mm Circlip is Jabiru P/No. PH0545N.

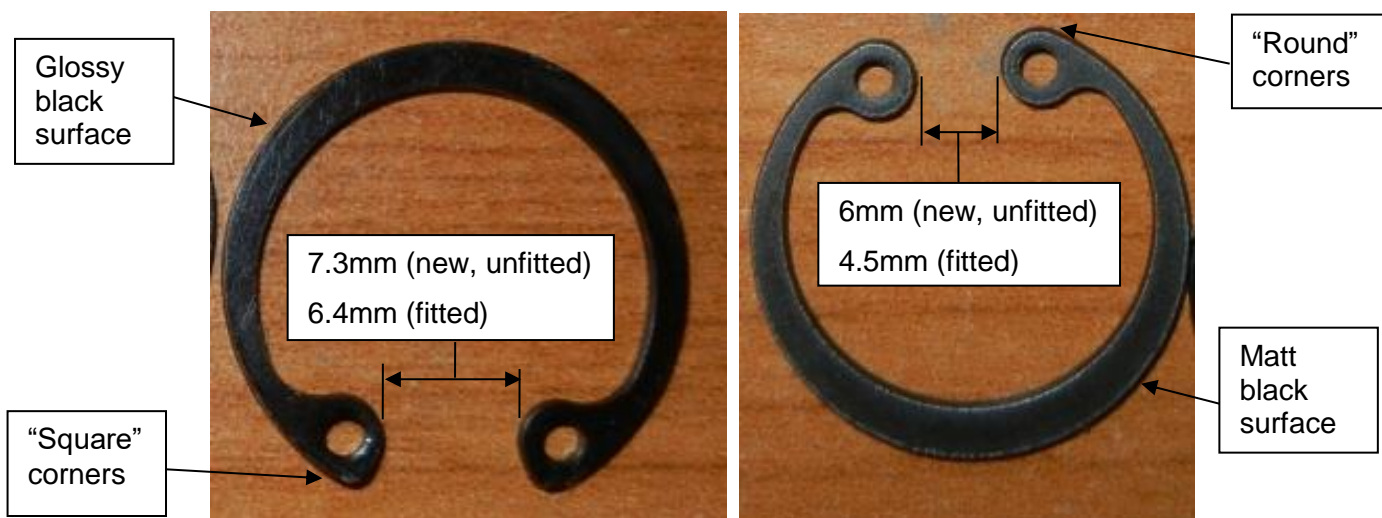

Figure 1 – Type A (Left) & Type B (Right) Circlips¹

2.1 Engines in Service

- Disassemble the engine and replace the 23mm circlips, pistons and gudgeon pins with current parts.
- **OR** Return the engine to Jabiru Aircraft or our local authorized representative for correction.

2.2 Engines in Storage

- Disassemble the engine and replace the clips, pistons and gudgeon pins with new parts.

¹ Dimensions for guidance only: may vary slightly.

Jabiru Service Bulletin: Piston Circlips			JABIRU AIRCRAFT PTY LTD P.O. Box 5186 Bundaberg West Queensland, Australia. Phone:+61 7 4155 1778 Fax:+61 7 4155 2669 Email: info@jabiru.net.au		
JSB 033-	Release Date: 28th April 2014	Effective Date: 28th April 2014	Affected Models: See Applicability	S/No. Range: See Applicability	Page 3 of 5

- Thoroughly inspect the pistons for damage or wear to the circlip groove. If wear or damage is noted contact Jabiru Aircraft for additional guidance.
- **OR** Return the engine to Jabiru Aircraft or our local authorized representative for correction.

3 Compliance – Implementation Schedule:

- Where date limitations are listed below the start date is taken to be the date of the effective date of this Service Bulletin - 28th April 2014.

3.1 Engines in Service:

- Within the next 5 hours in service or 6 months whichever is the sooner.
- The 5-hour allowance is provided to allow operators to ferry their aircraft to their place of maintenance.

3.2 Engines in Storage:

- Before the engine is used in an aircraft or within 12 months – whichever is the sooner.

Jabiru Service Bulletin: Piston Circlips			JABIRU AIRCRAFT PTY LTD P.O. Box 5186 Bundaberg West Queensland, Australia. Phone: +61 7 4155 1778 Fax: +61 7 4155 2669 Email: info@jabiru.net.au		
JSB 033-	Release Date: 28th April 2014	Effective Date: 28th April 2014	Affected Models: See Applicability	S/No. Range: See Applicability	Page 4 of 5

4 Procedure

4.1 General

- Refer to the current version of the Jabiru Engine Overhaul Manual (JEM0001) for engine assembly / disassembly procedures.
- Digital copies of the manual are available free of charge from the Jabiru Aircraft Australia Website; www.jabiru.net.au . Printed copies are available from Jabiru Aircraft Australia on request.
- Also note the supplementary details given in Section 4.2.
- Work called for by this Bulletin must be carried out by authorised personnel only. In Australia this generally means an RA-Aus Level 2 holder for other RA-Aus aircraft or a Licensed Aircraft Maintenance Engineer (LAME). The original builder of an Experimental-category aircraft may be approved in cases where they have undergone sufficient approved training (see local regulations for details).
- Any person carrying out this work on an engine must meet the maintainer requirements detailed in the current issue of the Jabiru Engine Overhaul Manual.
- Tools & facilities used in the completion of this work on an engine must meet the requirements detailed in the current issue of the Jabiru Engine Overhaul Manual.
- On completion of the work, the authorised person must note the completion of the actions required by this bulletin in the aircraft's maintenance logbook and the engine maintenance logbook (where applicable). This note should refer to the completion of maintenance requirements of this Service Bulletin, indicate details of the work completed, the date of the work and the identity (including licence number where appropriate) of the person carrying out the work.

4.2 Notes

- Clips must be oriented correctly on installation: See Figure 2: the clips must be fitted with the sharp-edged corner facing outwards.
- When installing clips compress them by the minimum amount required for fitting. DO NOT compress them until the eyes of the clip touch.
- Ensure the clip clips into the groove properly: there should be a crisp "click" as the clip fits into place. Visually and using a small screwdriver or pick, check that the clip is sitting evenly in the groove.
- Ensure that the opening in the clip is oriented as shown in Figure 2: it must face along the axis of the barrel.
- Ensure that the ends of the clip are both positioned within full-depth sections of the groove as shown in Figure 2.
- After fitting use a small screwdriver or pick to apply pressure to the clip as shown in Figure 2: the clip should not rotate. If the clip moves, discard it and fit a replacement.

Jabiru Service Bulletin: Piston Circlips

JABIRU AIRCRAFT PTY LTD

P.O. Box 5186
Bundaberg West
Queensland, Australia.

Phone:+61 7 4155 1778
Fax:+61 7 4155 2669
Email: info@jabiru.net.au

JSB 033-

Release Date:
28th April 2014

Effective Date:
28th April 2014

Affected Models:
See Applicability

S/No. Range:
See Applicability

Page 5 of 5

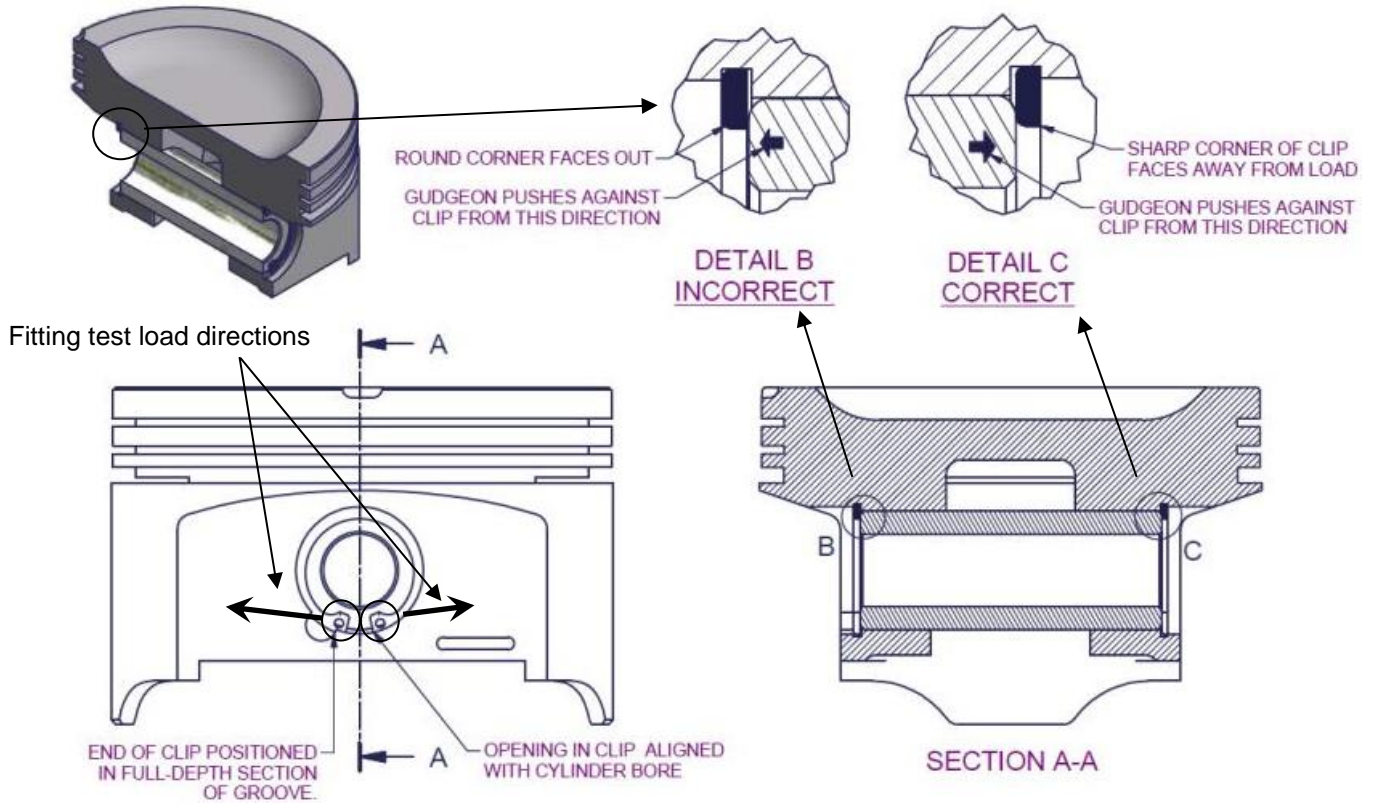

Figure 2 – Clip Installation Details

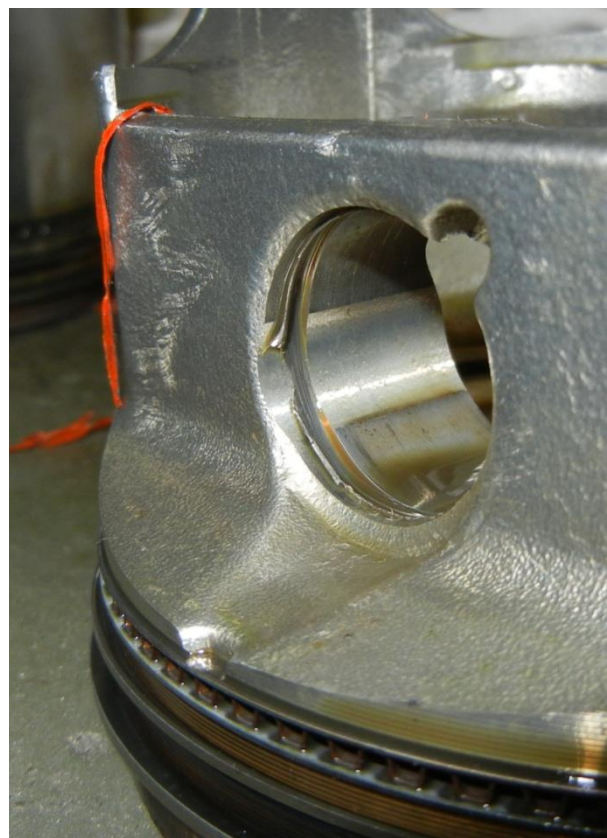

Figure 3 – Worn Circlip Grooves.

Jabiru Service Directive: Piston Circlips		JABIRU AIRCRAFT PTY LTD P.O. Box 5186 Bundaberg West Queensland, Australia. Phone:+61 7 4155 1778 Fax:+61 7 4155 2669 Email: info@jabiru.net.au			
JSD 033-2	Release Date: 28th April 2014	Effective Date: 28th April 2014	Affected Models: See Applicability	S/No. Range: See Applicability	Page 1 of 1

SAFETY DIRECTIVE: JSD 033-2

Issue: 1

Subject: Piston Circlips

Release Date: 28th April 2014

Effective Date: 28th April 2014

Affected Models: Jabiru 2200 & 3300 Engines

Affected S/No: As Detailed on Page 1 of JSB033-2

Requirement:

- Operators of engines in the Serial Number ranges given within Light Sport Aircraft categories must comply with the requirements of Jabiru Service Bulletin JSB 033-.

Compliance:

- The compliance details given in JSB 033- must be met.

Background:

- This Safety Directive has been prepared to make mandatory the requirements of JSB 033- for engines operating within Light Sport Aircraft Categories.