



Post-Paint>Wings>Prepare wings for fitting

Objectives of this task:

To prepare the wings prior to fitting them to the fuselage.

Materials required:

Resin and flock

Card #16 'Flaps'

Prepare the flaps

Run a 3/16" drill through the bolt hole in each flap hanger to clear any paint and debris out of the holes. Clean out the 1/4" holes in the flap pivot arms in a similar manner.

The flaps will be fitted to the wings after the wings have been fitted to the fuselage.

Fit the ailerons

Hold the aileron in place and slide the hinge pins through each hinge, starting from the side of the hinge where the pin retaining slot was filed in the *Pre-Paint>Wings>Fit ailerons* task.

Fit the pin retainers and hold them in place with a 5/32" machine thread screw.

Place the ailerons in the neutral position and place a length of cloth tape over the top surface of the wing and the aileron. This will prevent the ailerons from dropping when the wing is turned right way up.

Turn the wings over so that they are right way up.

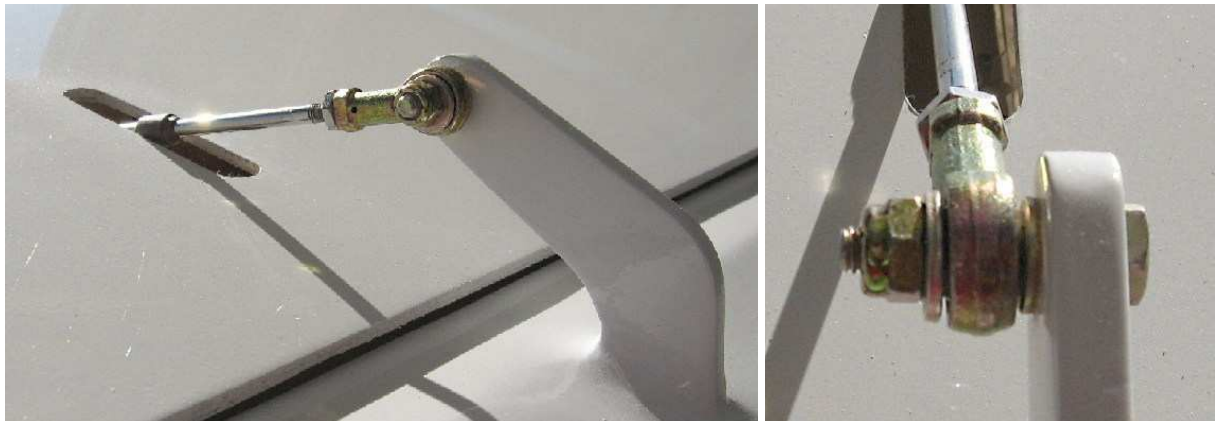

Fit the aileron cable rod end to the aileron drive arm with an AN3 bolt fitted through the drive arm, then an AN960-416 (3/16") flat washer, then the rod end followed by an AN960-515 (1/4") flat washer and a Nyloc nut as shown in the photos above.

Tighten the Nyloc nuts to safety and mark with *Torque Seal*.

Fit the fuel gauges

Remove the masking tape from over the fuel gauge boss in the wing root and clean the area.

Test fit each fuel gauge – feed the float unit into the wing tank and hold the gauge in place with 2 screws. Check the empty indication – the needle should sit slightly below the “E” or “Empty” mark as shown in the photo at top right.

If it does not then the gauge will need to be adjusted.

The gauge needle is driven by a magnet that is turned by the action of a float that sits inside the fuel tank. The gauge can be disassembled by pulling the black nylon float drive out of the aluminium gauge body and the magnet can be twisted slightly by hand. See the photos below for detail of the gauge unit.

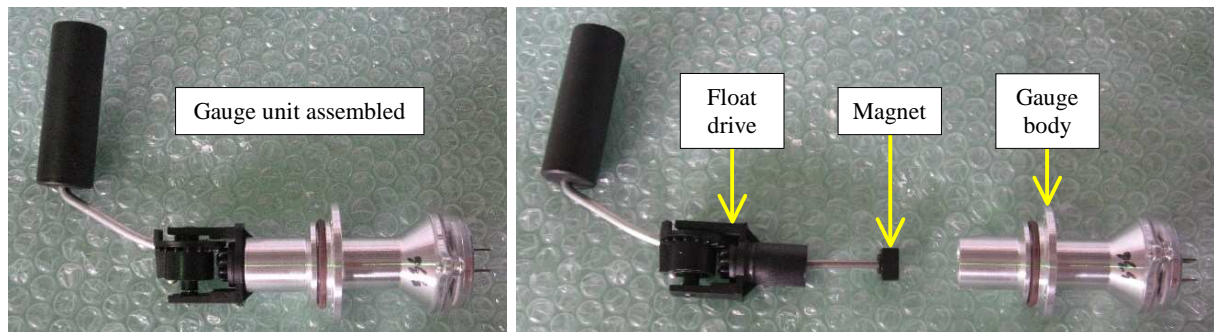

The gauge can then be reassembled and rechecked (and readjusted if necessary) until it reads correctly.

The nylon drive unit barrel should be a firm fit into the gauge body: if the fit is not entirely to your satisfaction then a smear of Loctite 577 *Sealant* should be applied to the barrel.

When the gauges are fitted each of the 4 retaining screws and the top and bottom gauge face screws should have a small drop of Loctite 242 *Threadlocker* applied before fitting.

Carefully bend the electrical spade terminals out so that they are parallel to the face of the gauge as shown circled at right.



Fit the fuel tank connector blocks

Fit the tank connector blocks through the slots in each side of the fuselage and push each connector block fully forward in the slot.

Use the supplied layer plate as shown in the photo at right to hold the connector blocks in the fully forward position and fix to the fuselage with 2 x 8G stainless steel self-tapping screws.



Fuel lines and fittings



There are 3 fuel lines that need to be connected in the wing root: the bottom 2 carry fuel to the header tank while the top line is the breather for the header tank. These fuel lines each need to be fitted and then cut to an approximate length of 300mm behind the rear of the wing.

All 3 lines exit the wing root towards the rear and both of the fuel lines will have a spring fitted to prevent any chance of a kink developing when the lines are bent to the rear, while the breather line faces rearwards already.

Fit each fuel line to the tank fitting and secure with a hose clamp. Slide a 100mm length of spring over each fuel line, push all the way up to the hose clamp and fix in place with silicone sealer at the hose clamp end as shown in the photo at right.

Label the other end of each fuel line with tape as shown at right. This is essential because once the wing has been fitted it will be *very* difficult to determine which line is which if it has not been labelled.

“**B**” = breather line

“**F**” = front fuel line

“**R**” = rear fuel line



Fit the fuel gauge windows

Locate the clear, round fuel gauge windows and Superglue them over the outside of the fuel gauge holes in the wing root area of the fuselage.

Fit the vent tubes to the fuel filler caps

The fuel filler caps came partly assembled on the card head and were fitted to the fuel filler opening on the wing in the *Pre-Paint > Wings > Prepare wing root* task to keep dirt out of the wing tanks, all that remains now is for you to fit the vent tubes to the fuel caps.

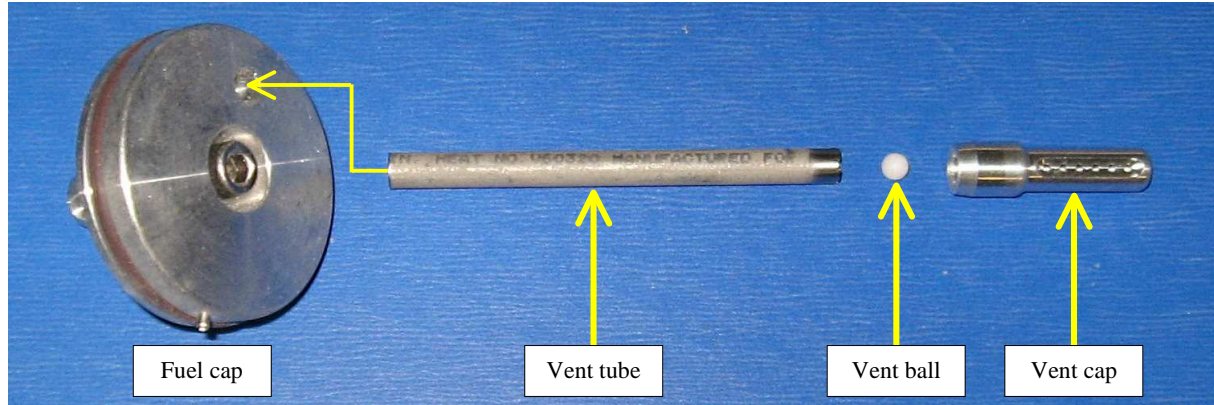

Working on one wing at a time, remove the fuel cap and place a clean cloth or a piece of tape over the fuel filler opening so that no dirt or debris can fall into the tank during this process. Start by carefully cleaning away any paint from the top of the fuel cap and in particular from the vent tube hole in the top of the cap.

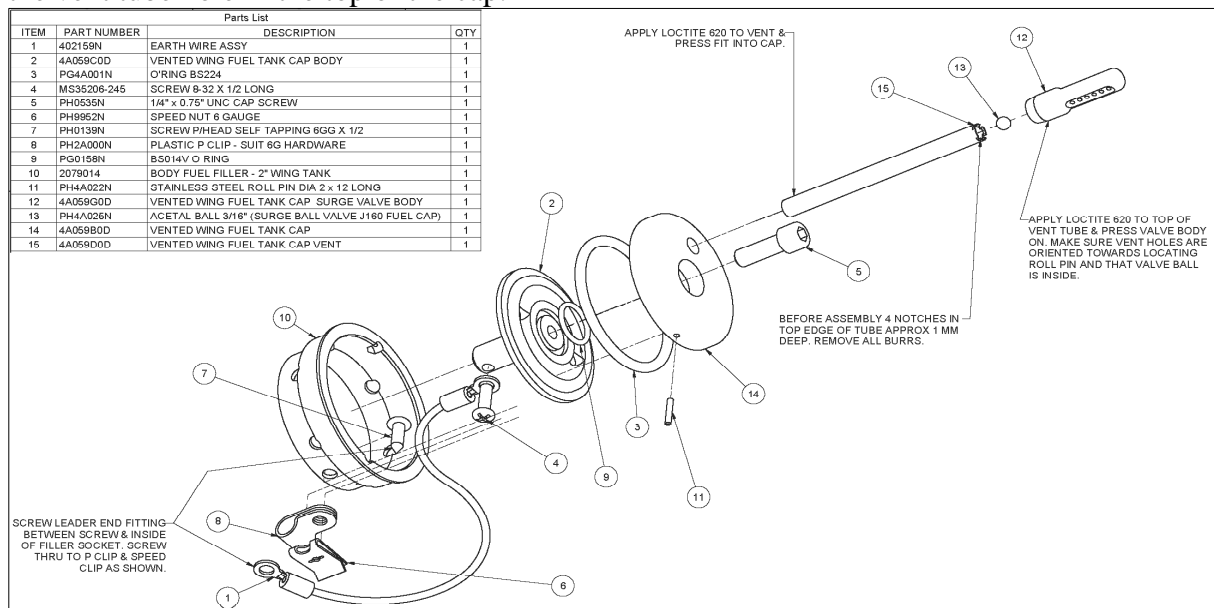

Use a file to cut 4 notches each 1mm deep into the top of the vent tube. Remove all burrs.

Fit the notched end of the vent tube to the vent cap – the vent tube should be a snug fit into the vent cap, use fine sandpaper if required to size the tube to a good fit. Now, working upside down, drop the small white vent ball into the vent cap and use a smear of Loctite 620 to fix the vent tube into the vent cap. Make sure that nothing has caught the vent ball – the ball should still rattle in the vent cap when the assembled tube and cap is shaken.

Fit the vent tube to the hole in the top of the cap – the vent tube should be a snug fit into the hole, use fine sandpaper if required to size the tube and then fix it in place with Loctite 620 with the breather holes in the vent cap facing towards the outside of the fuel cap.

This completes the *Post-Paint > Wings > Prepare wings for fitting* task.