

Post-Paint>Fuselage>Interior>Fit console controls

Objectives of this task:

To fit all of the console controls: the control stick, elevator trim and brake system.

Materials required:

Card # J17 'Elevator System and Control Stick'

Card # J8 'Dual Brakes'

Card # J2 'Trim System'

Control stick

Fit the 2 eccentric aileron stops to the rear end plate with 2 Allen head cap screws as shown at right.

The control stick should still be partly assembled from the *Pre-Paint>Fuselage>Interior> Console>Fit Control Stick* task. Clean any debris from the front and rear bushes and apply a small amount of lubricant to the bushes. Fit the control shaft into the console from the front, wipe away any lubricant from the rear of the control shaft and fit the aileron bellcrank to the rear of the shaft with an AN3-16A bolt and Nyloc nut, with the bolt fed up through the bellcrank.

Refer to the drawing on the next page for detail.



Fit the control stick to the pivot plate with an AN3-13A bolt, taking care to fit a flat nylon washer on each side between the stick and the plate. Connect the elevator cable rod end to the control stick with an AN3-21A bolt, spacer, 1/4" flat washer and a Nyloc nut as shown in the photo above and in the drawing on the next page.

Check for full and free movement of the control stick.

ITEM	PART NUMBER	DESCRIPTION	QTY
1	1007094-4	BUSH - CONTROL COLUMN	1
2	3A081B0D-1	CENTRE STICK PIVOT SHAFT	1
3	3A026E0D-5	DOUBLE CENTRE STICK PIVOT PLATE	1
4	3117094-2	POLYURETHANE WASHER 10mm ID, 25.4mm OD, 1 THICK (NOT DRAWN)	2
5	3000C84-5	SPACER CENTRAL PIVOT	4
6	AN960-10	3/16" FLAT WASHER	9
7	MS20365-1032	3/16" NYLOC NUT	5
8	ANS-13A	3/16" BOLT	3
9	ANS-21A	3/16" BOLT	1
10	ANS-16A	3/16" BOLT	1
11	AN960-416	1/4" FLAT WASHER	1
12	PB00184	3/16" FEMALE ROD END	1
13	PM0055N	END CAP	2
14	PM0039N-cut	RUBBER HAND GRIP	2
15	3A026F0D-6	DOUBLE CENTRE STICK HANDLE ASSY	1
18	PI0092N-1	PTT SWITCH (SPST MOMENTARY ON, 3A-125V/1A-250V)	2
19	3A087D0D-2	AILERON BELLCRANK INBUILT STOPS	1
20	3A087A0D-1	ASSY - CONTROL SHAFT END HIGH AIL STOPS, SKF BEARING	1
21	MS35207-267	SCREW 10-32 X 3/4	2
22	ANS16-3	3/16" NUT	2

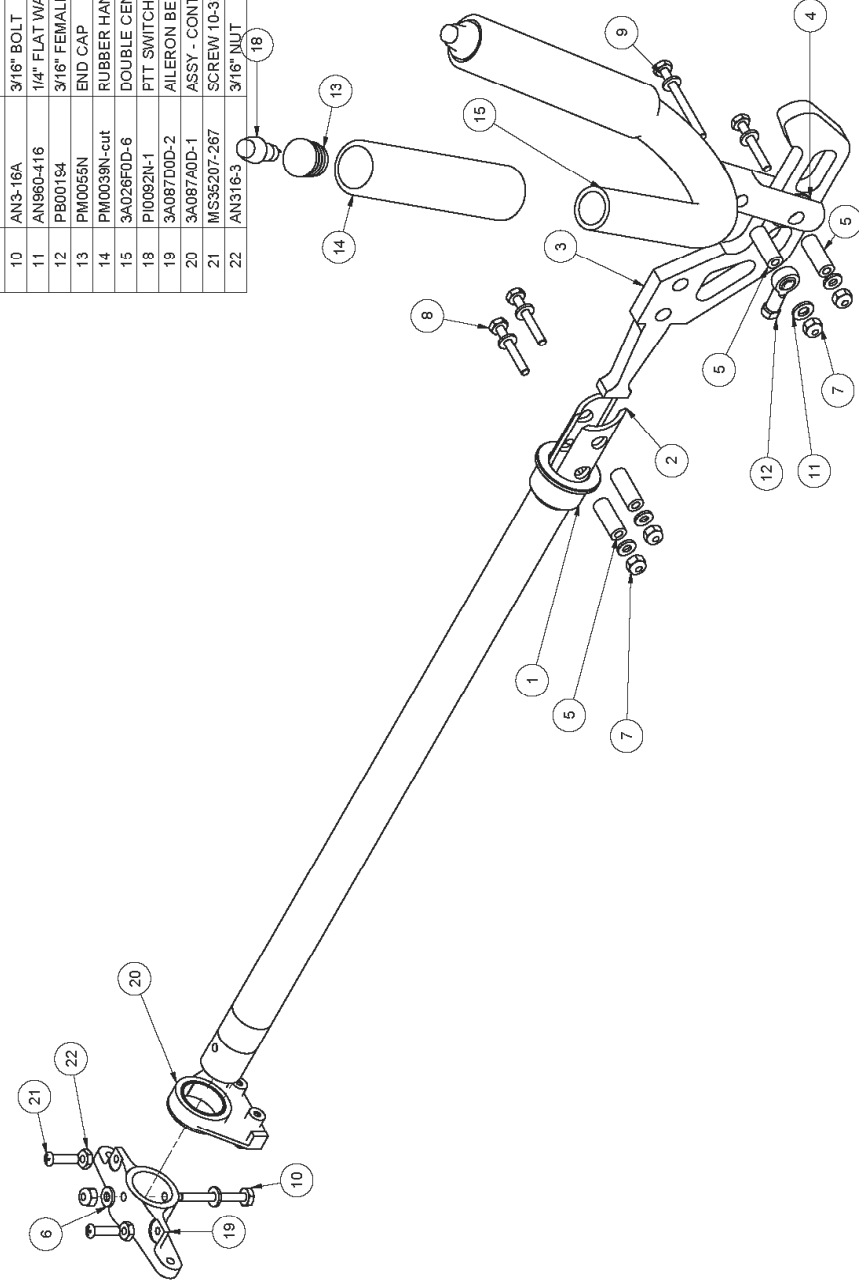

PROJECTION	DIMENSIONS IN MILLIMETRES	DO NOT SCALE	AVTECH P/L A.C.N. 010 786 973 HINKLER AIRPORT BUNDBERG 4670	THIS DRAWING IS COPY RIGHT AND MUST NOT BE COPIED WITHOUT THE CONSENT OF AVTECH PTY LTD TITLE CONTROL STICK ASSY J160 HIGH AILERON STOP	SCALE NTS 1 050506 ISS. DATE
GENERAL TOLERANCES WHOLE NO'S ± 0.5 ONE DEC. ± 0.25 TOW. DEC. ± 0.05 ANGLES ± 0.5° MATERIAL REFER TO PART DRAWINGS	DRAWN JW	APPR.	DWG. NO. 3A081A0D-4	SHEET 1 OF 1	4/6/07 12/4/07 28/11/06

Brake system

Cut a short length of sheet aluminium the width of the brake lever slot and about 40mm in length. Bend the aluminium strip in half, apply a smear of Araldite inside the bend and crimp it to the front of the brake lever slot – this is the bearing surface for the brake lever cam.

The brake lever should still be assembled from the *Pre-Paint>Fuselage>Interior>Console>Pre-Fit Handbrake* task: fit the brake lever mount bracket to the front inside of the console and secure with 2 x ¼” by ½” UNC Allen head cap bolts and flat washers. Fit the lever into the bracket with an AN4-11 bolt and castle nut, with a thin flat washer on each side of the lever, tighten the castle nut firmly and lock it in place with a split pin.

Hint: a magnet will help you place the flat washers.

Refer to the drawing on the next page for detail.

Fit the master cylinder to the front of the console with 2 x ¼” by ¾” UNC Allen head cap bolts and fit the clevis to the bottom of the lever with an AN5-11 bolt and castle nut, tighten the castle nut firmly and lock in place with a split pin.

Drill a ½” hole near the top left of the front face of the console and feed the brake hose into the console then down and out of the hole behind the top of the main undercarriage legs. Fit a rubber grommet over the brake hose at the front of the console, blow the hose clear and fit it to the brass fitting on the master cylinder. Tighten the fitting firmly. Leave the brake hose about 50mm below the fuselage and trim off.

Fit a brass “T” connection to the hose, then run a length of brake hose down each main undercarriage leg to each brake assembly as shown in the photo at right. The short length of PVC tubing over the brake hose is to protect against chafing from the wheel spat. Zip tie the brake hose to the leg.

Check that all of the brake hose fittings are tight.

Fill the reservoir on the master cylinder with the recommended brake fluid, loosen the bleed valves on the wheel cylinder units (circled in yellow above) and slowly pump clean brake fluid through the brake lines.

Pay careful attention to the brake fluid level in the master cylinder reservoir during this procedure and keep the fluid level topped up, otherwise you run the risk of drawing air back into the lines, which would mean starting all over again.

When brake fluid reaches the wheel cylinders close off each bleed valve and then pressure bleed each wheel cylinder in turn until no more air remains in the brake lines and the brake lever feels firm and not at all spongy when pressure is applied.

When you are satisfied with the brake pressure, top up the fluid and replace the reservoir cap.

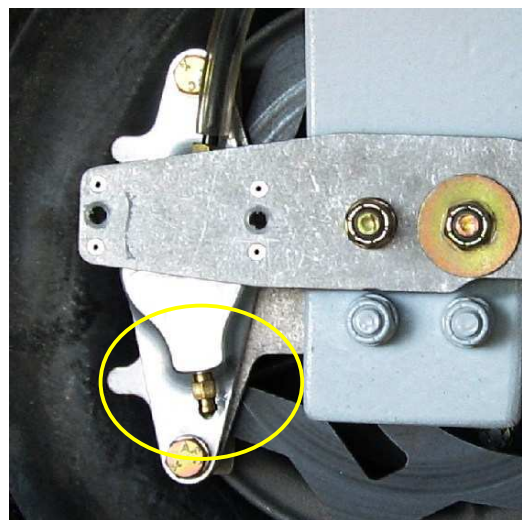

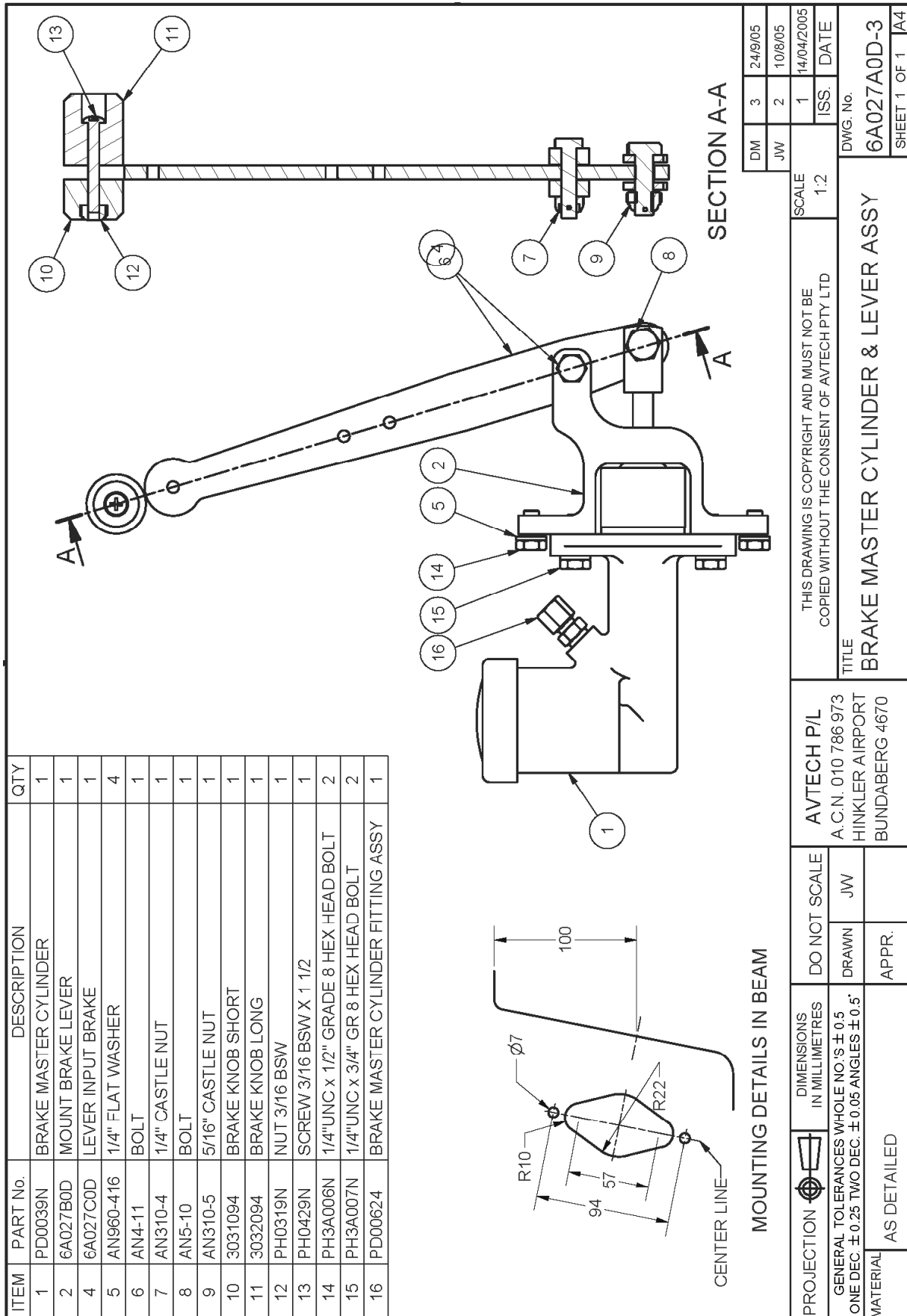

ITEM	PART No.	DESCRIPTION	QTY
1	PD0039N	BRAKE MASTER CYLINDER	1
2	6A027B0D	MOUNT BRAKE LEVER	1
4	6A027C0D	LEVER INPUT BRAKE	1
5	AN960-416	1/4" FLAT WASHER	4
6	AN4-11	BOLT	1
7	AN310-4	1/4" CASTLE NUT	1
8	AN5-10	BOLT	1
9	AN310-5	5/16" CASTLE NUT	1
10	3031094	BRAKE KNOB SHORT	1
11	3032094	BRAKE KNOB LONG	1
12	PH0319N	NUT 3/16 BSW	1
13	PH0429N	SCREW 3/16 BSW X 1 1/2	1
14	PH3A006N	1/4"UNC x 1/2" GRADE 8 HEX HEAD BOLT	2
15	PH3A007N	1/4"UNC x 3/4" GR 8 HEX HEAD BOLT	2
16	PD00624	BRAKE MASTER CYLINDER FITTING ASSY	1

THIS DRAWING IS COPYRIGHT AND MUST NOT BE COPIED WITHOUT THE CONSENT OF AVTECH PTY LTD		SCALE 1:2	DM 3 24/9/05 JW 2 10/8/05
TITLE BRAKE MASTER CYLINDER & LEVER ASSY		ISS 1 14/04/2005 DATE	DWG. No. 6A027A0D-3
AVTECH P/L A.C.N. 010 786 973 HINKLER AIRPORT BUNDABERG 4670		DO NOT SCALE DRAWN JW	SHEET 1 OF 1 A4
DIMENSIONS IN MILLIMETRES		APPR.	
GENERAL TOLERANCES WHOLE NO.'S ± 0.5 ONE DEC. ± 0.25 TWO DEC. ± 0.05 ANGLES ± 0.5°		AS DETAILED	

Elevator trim lever assembly

Connect the trim cable rod end to the left-hand trim lever with an AN3-10A bolt, 3/16" and 1/4" flat washers and a Nyloc nut. Clean any debris away from the trim bush and fit the trim shaft and levers, with soft washers under the levers, and secure the levers to the shaft with an AN3-35 bolt and castle nut. The castle nut should be fitted to the left-hand side of the console, tightened firmly and locked in place with a split pin as shown in the photo at right.

Check for full fore and aft stop-to-stop movement of the trim levers.

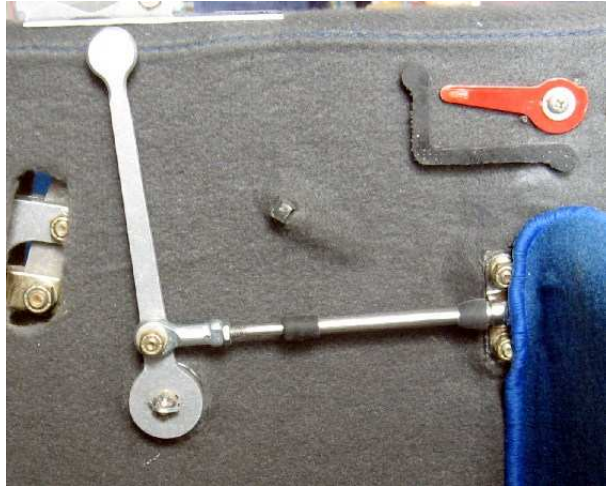

Pitot tubing

Use a flexible rod to draw a length of 1/4" ID PVC tubing through from the wiring access hole in the lower front of the console, through the console and out of the hole under fuselage where the brake line exits.

Leave enough length so that the top of the tubing is just below the bottom of the windscreen and so that the bottom of the tubing reaches across to the right-hand strut bushing.

The top end of the pitot tubing will be connected in *Post-Paint>Fuselage>Interior>Fit the instrument panel* and the bottom end will be connected once the wings have been fitted.

Fuel tap

Fit the red fuel tap handle to the fuel tap shaft as shown in the photo at right.

Position the "L" shaped plastic guard in front of and below the tap, drill holes for the end pegs and Araldite the guard into place.



Placards

Place the fuel tap placard behind the fuel tap.

Place the trim placard above the trim lever on top of the console with the front of the placard level with the front of the brake lever slot.

Place the brake lever placard behind the brake lever slot with the rear of the placard level with the rear of the trim placard.

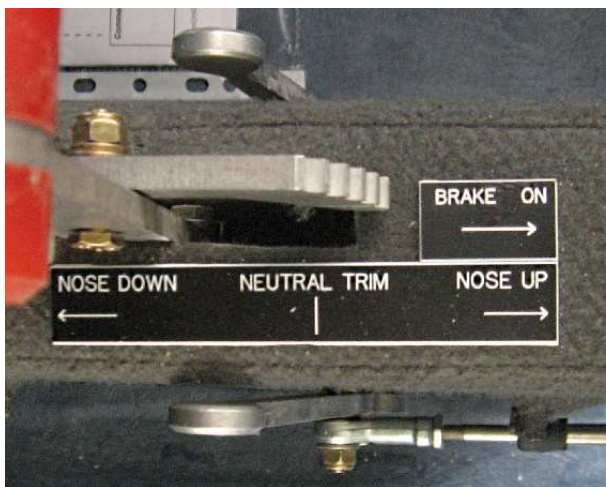

This completes the *Post-Paint>Fuselage>Interior>Fit console controls* task.