

DOORS: CARD T1-2

7A006A0D x 2

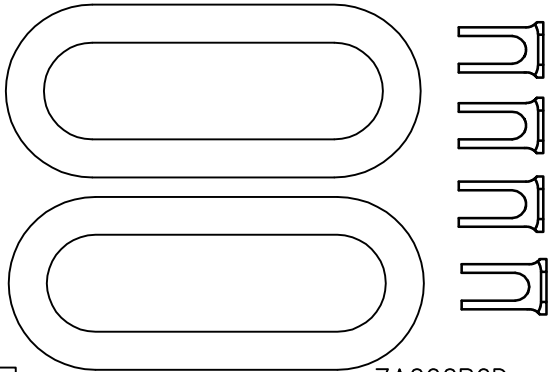

7A000B0D x 4

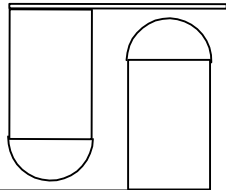

PH9A011N DOOR LATCH 2 PACK

HEATSHRINK
RED 22MM X
200MM

AN3-35 x 1
AN310-3 x 1 Castle Nut
AN960-416 x 1
AN3-10A x 1
Bundy Tube 8mm x 4
PB0099N x 1 3/16 Male Rod Ends
AN380-2-2 x 3
PH7A002N x4 3/16x3/4unc CapScrews
PAN 6g x 3/4 s/s x 4 PH3A001N
MS24693S275 CSK x 4
AN960-10 x 4
MS20365-1032 x 5 Nyloc Nut
AN380-1-2 x 1 Split pins
TLR RIVETS X 6

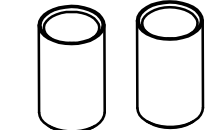

7A014B0D X 2

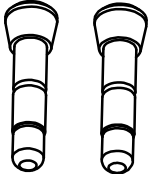

7A014C0D X 2



Door strao Webbing x 25mm



7A008A0D X 2

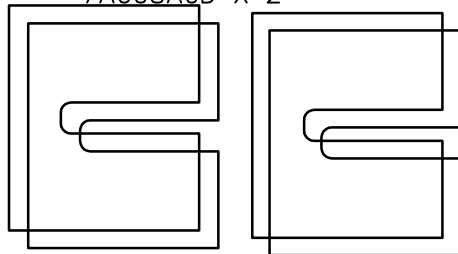

1A082A0D X 4

3m DOOR SEAL ATTACHED IN THE CARD BOX (WHITE ONLY)

TRIM SYSTEM: CARD T2-2

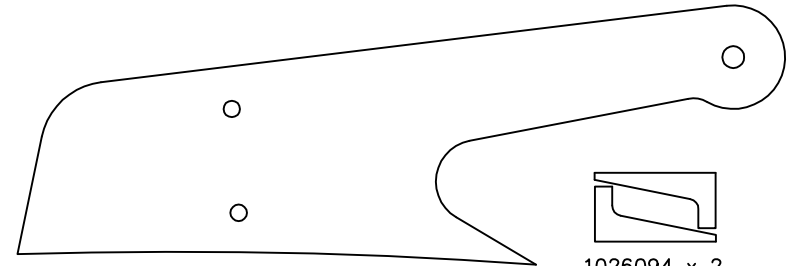
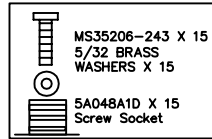

3065094 x 1

1026094 x 2

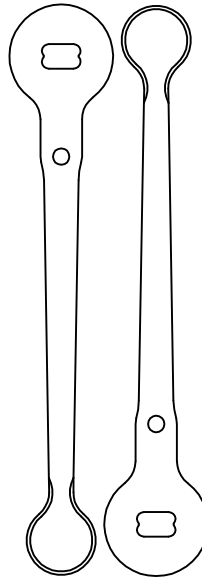

3A060E0D x 2

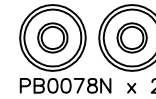

3A070A0D X 1

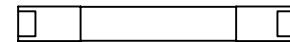
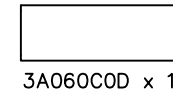
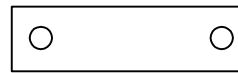

3129014 x 2

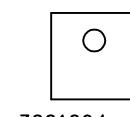

3102284 x 1



3131014 x 1

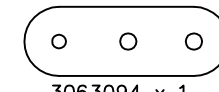
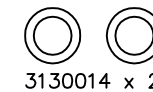
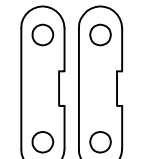
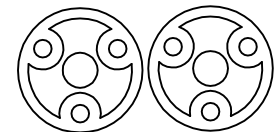
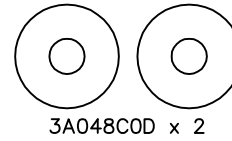
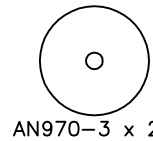
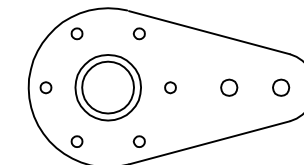
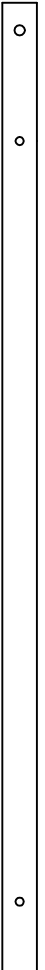

5009094 X 1

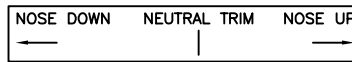
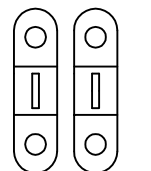

5A031A0D x 1

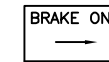

5A031B0D x 1

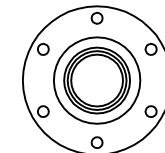

5061054 x 1 (VHF Aerial)

CARD T3-4: RUDDER

3A006D0D x 6

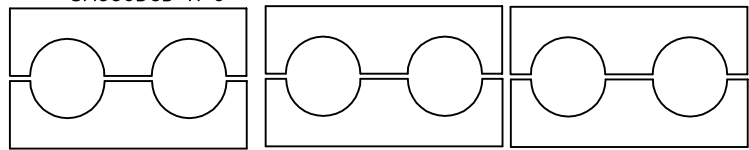

3A041A0D x 3

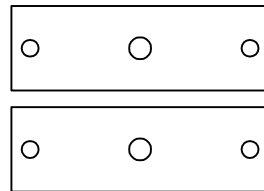
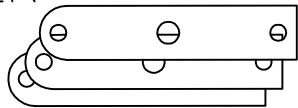

3015094 x 2

3233014 x1

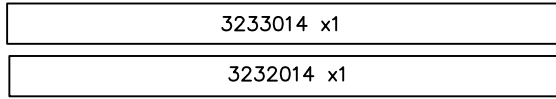

3232014 x1

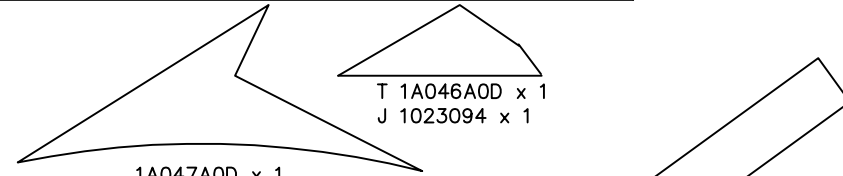

1A047A0D x 1

T 1A046A0D x 1
J 1023094 x 1

HARDWARE LIST	
PH115434	x 2 CAP SCREW
PH0239N	x 6 (1/4 PLAIN NUTS)
AN4-23A	x 1
AN3-23A	x 2
AN3-25A	x 4
AN4-14A	x 2
AN4-25A	x 3

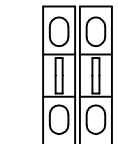

PC0089N x 2

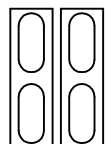

PC0099N x 2

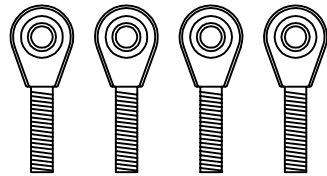

PB0112N x 4

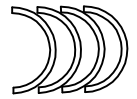

3014094 x 4

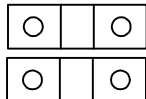

3224004 x 2

5 LINKS

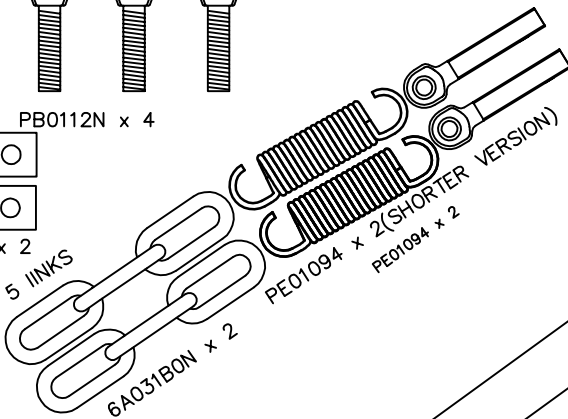

6A031B0N x 2

PE01094 x 2 (SHORTER VERSION)

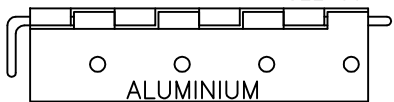

ALUMINIUM

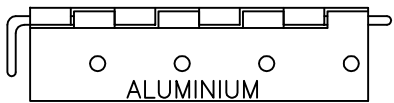

ALUMINIUM

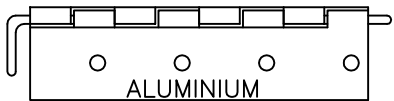

ALUMINIUM

2001394 x 3

CARD T4-4: PANEL MOUNT THROTTLE COMPONENTS STANDARD/JUMBO

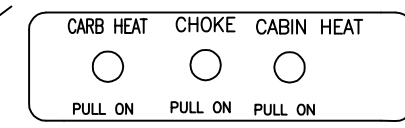

5A030A0D x1



PB0009N x 2

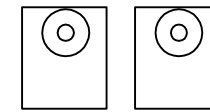

3A005F0D x 2

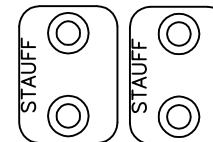

PZ0059N x 2

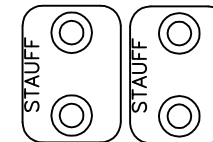

PZ0059N x 2

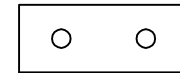

3128004 x 2

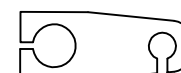

3067134 x 1

HARDWARE LIST	
AN3-22A	x 2
AN380 2-2	X 1 Split pin
PH0778N	x 3 GRUB SCREW
3/8 x 1 3/4"	BRASS SCREWS X 4
AN4-13A	x 2
AN970-3	x 2 PENNY WASHER
AN3-11A	x 5



3A005L0D x 3

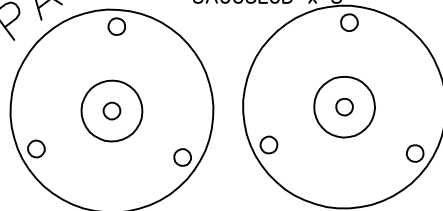

3A005H0D x 2

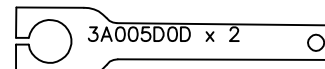

3A005D0D x 2

3A005B0D x 2

3A005E0D x 2

CARD T7-3: UNDERCARRIAGE

T DESCRIPTION	QTY
AN3-15A	2
AN4-22A	2
AN4-25A	2
AN6-26A	2
AN6-27A	4
AN6-24A (J170 LIGHT)	6

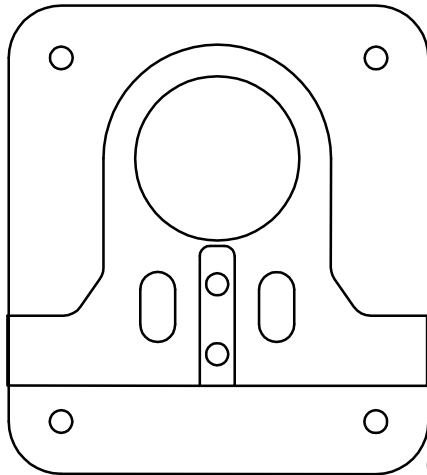
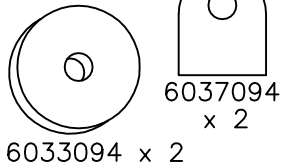

6A003F0D-2 x 1
6A003B0D x 2

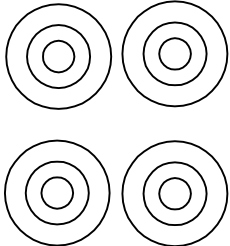

6034094 x 4
BUSHES

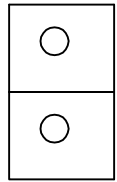

6036094 x 4

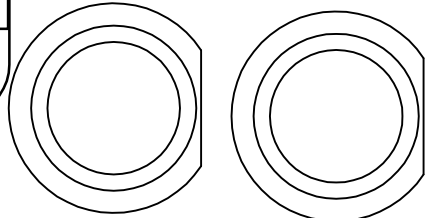

6194104-1 x 2

T 6A003H0N x 1

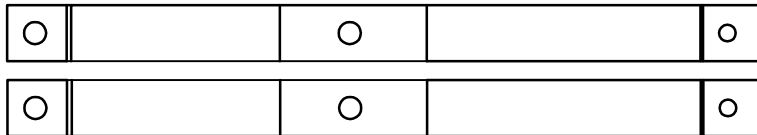

T 6A003G0D x 1

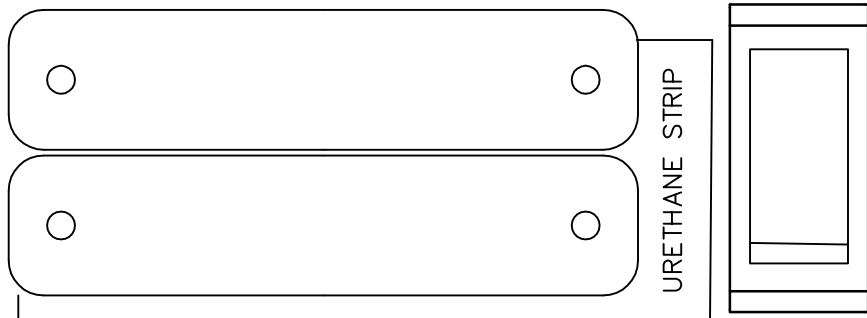
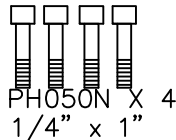

6003094 x 2
620302N x 2

6A003D0D x 1

CARD T7-3: UNDERCARRIAGE

T DESCRIPTION	QTY
AN3-15A	2
AN4-22A	2
AN4-25A	2
AN6-26A	2
AN6-27A	4
AN6-24A (J170 LIGHT)	6

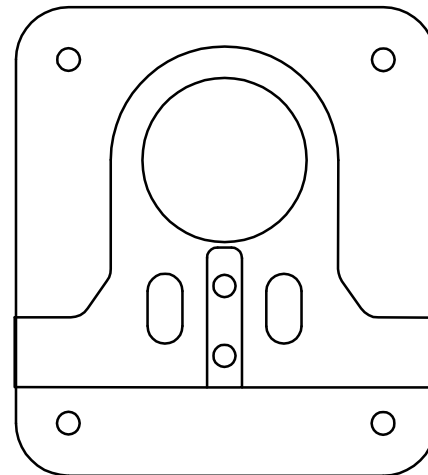
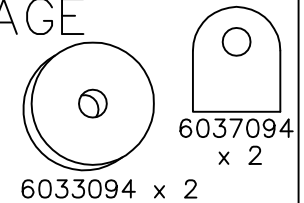

6A003F0D-2 x 1
6A003B0D x 2

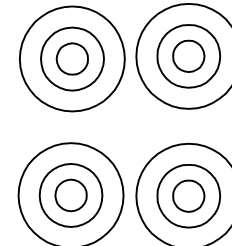

6034094 x 4
BUSHES

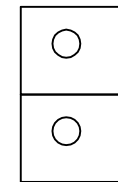

6036094 x 4

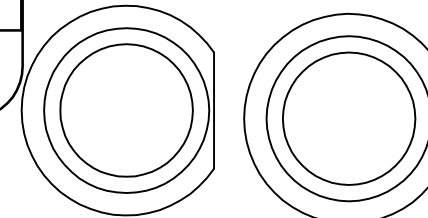

6194104-1 x 2

T 6A003H0N x 1

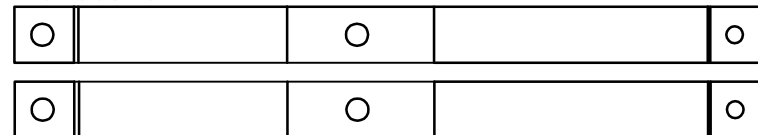

T 6A003G0D x 1

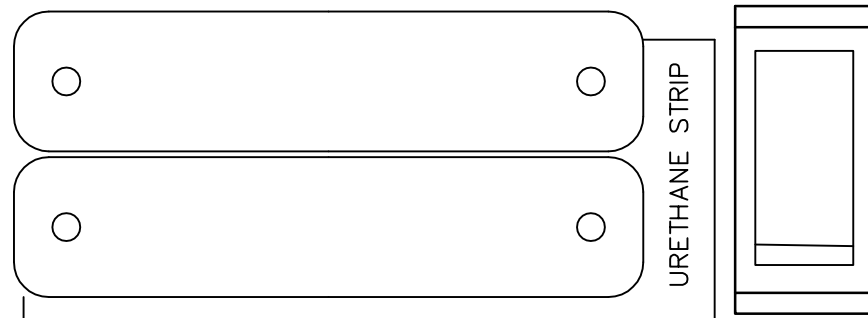
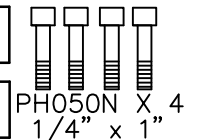

6003094 x 2
620302N x 2

6A003D0D x 1

CARD T 8: BRAKES

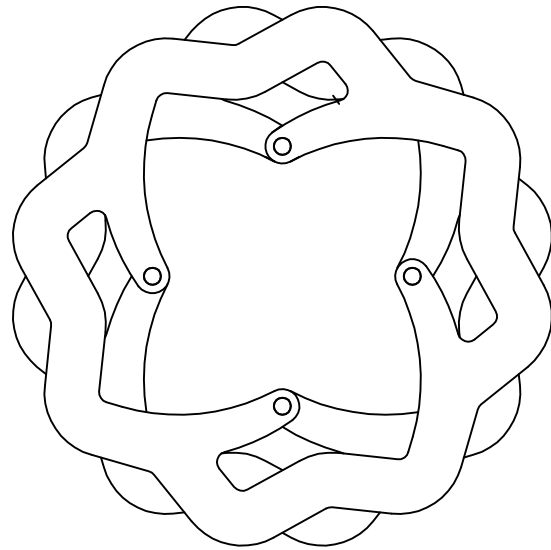

6A040A0D x 2

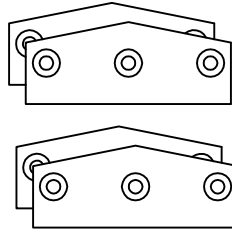

6000994 x 4



3060094 X1

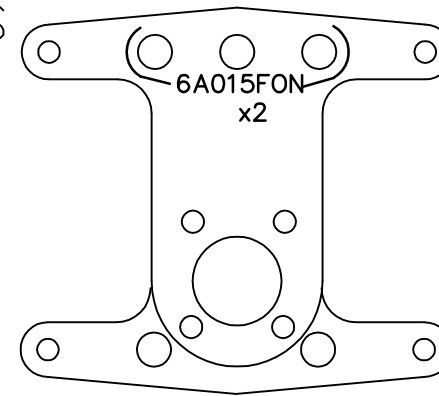

6A015FON
x2

PH72625 UNC X 3/8
CAP SCREW X2
1/4 UNC X 1 PH0505N
CAP SCREW X 2
AN4-11A X 1
AN5-10A X 1
MS21045-4 X 4
AN4-15A X4
PH1200N X7 Rivets
PH1210N X7 Rivets
AZ2-03 X 2 Fitting
3/16" FERRULE x 2
6100094x2 Nipple
PX0029Nx4 Spring
3/16 BSW 1 1/2"x1
3/16 NUT BSW x 1

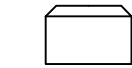

3031094 x 1

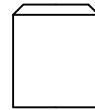

3032094 x 1

BREAK HOSE X 3.5M



MASTER CYLINDER
STRAIGHT FITTING x 1
PD00624

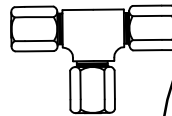

PG3A008N x



1A003A0D x1
Brake Lever Stop

1/2 Blanking Grommet
PW0069N x 1

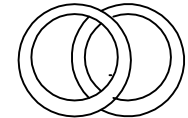

BS0214 x 2 O-RINGS

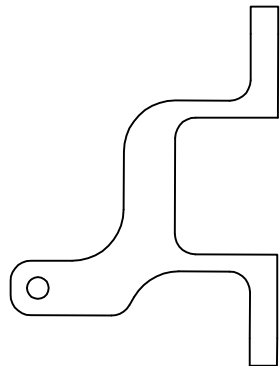

6A027B0D x 1

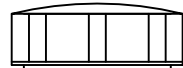

FLUID FLOW

PD0039 x 1

Brake Master Cylinder.

PBR

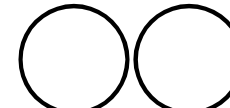
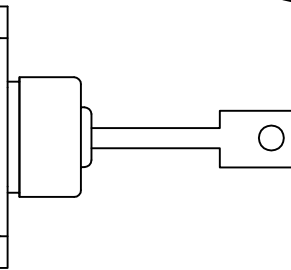

6207224 x 2
BRAKE PISTON

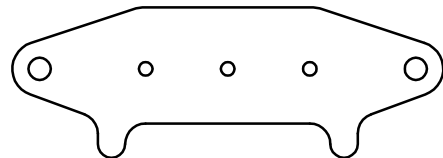

6A018COD x 2 CFI ONLY

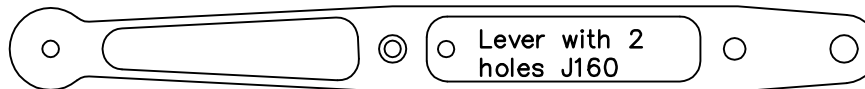

6A027C0D X 1

Lever with 2
holes J160

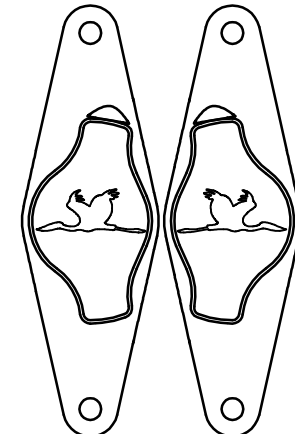

620762N x 1,
6207124 x 1

CARD J8-2 : DUAL BRAKES



6207224 x 4
BRAKE PISTON
BREAK HOSE X
3.5M

Brake Lever Stop
cover x 1
1A003A0D

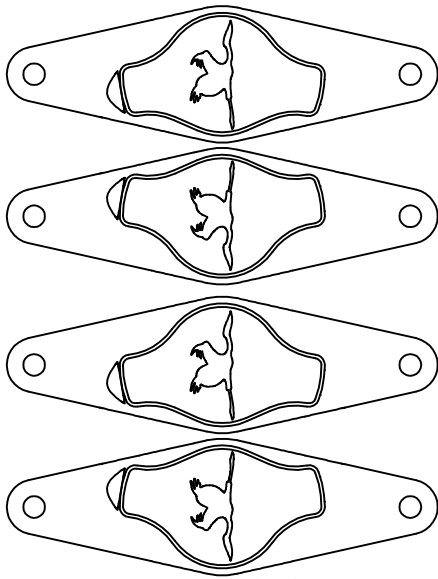

620762N x 2(LH)
6207124 x 2 (RH)

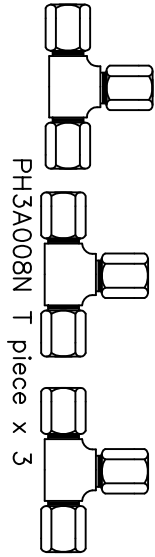

PH3A008N T piece x 3

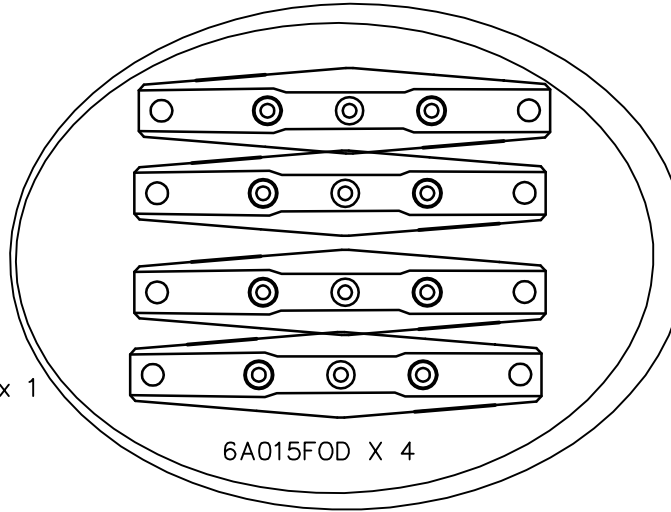

6A015FOD X 4

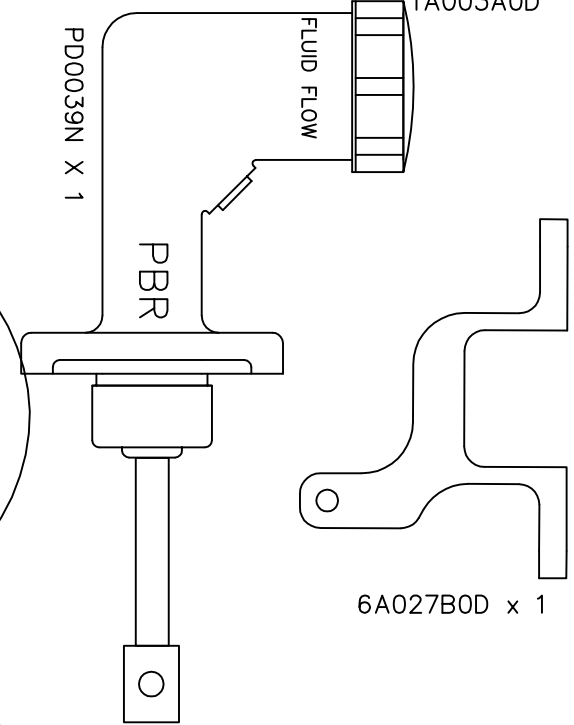

PD0039N X 1

PBR

FLUID FLOW

6A027B0D x 1

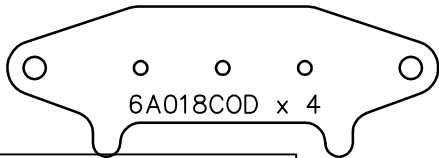

6A018COD x 4

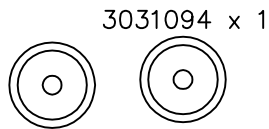

3032094 x 1

3031094 x 1

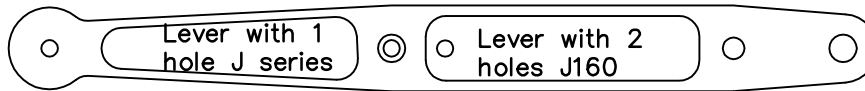

Lever with 1
hole J series

Lever with 2
holes J160

6A027COD X 1

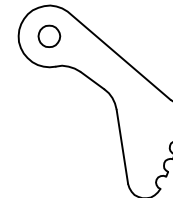

3060094 x 1

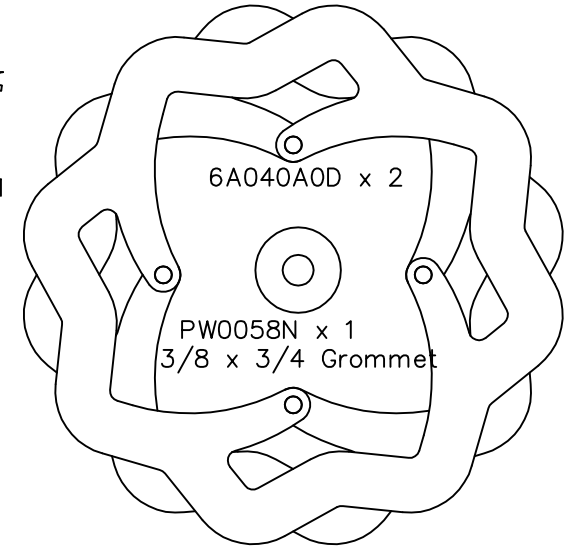

6A040A0D x 2

PW0058N x 1
3/8 x 3/4 Grommet

SMALL PARTS
1/4 unc 1" cap X2
AZ2-03 x 4 BRAKE CYLINDER FITTING
6100094-3 x 4
PH1200N X 14 BRAKE RIVETS
PX0029N X 8 BRAKE SPRINGS
3/16" FERRULE x 4
AN380-2-2 x1 Split pin
3/16 BSW 1 1/2" x 1
1/4 unc X 5/8 capX2
AN4-15A x 8
MS21045-4 x 8
AN960-416 x 8
AN5-10A x 1
AN4-11A X 1
PH1190N X 14 BRAKE RIVETS

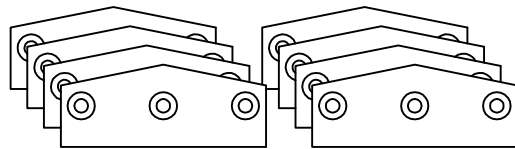

6000994 x 8

MASTER CYLINDER
STRAIGHT FITTING
PD00624 X 1

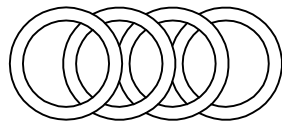

BS0214 x 4 O-RINGS

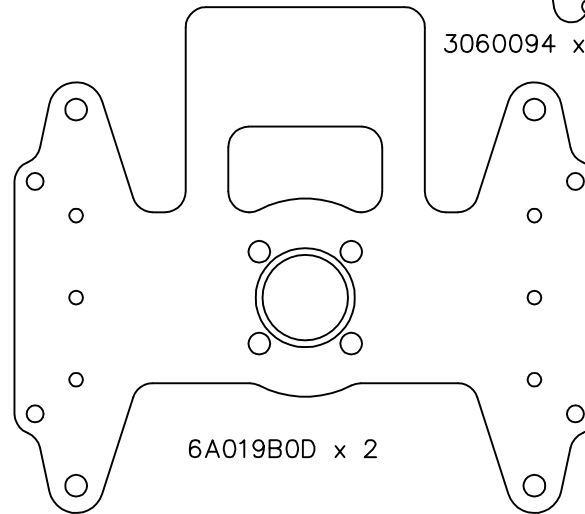

6A019B0D x 2

CARD T9-2: SEATBELTS

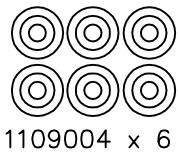

1109004 x 6

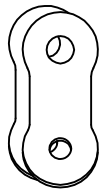

1108104 x 2

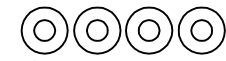

P/N0 AN960-516 x 4



P/N0 MS20365-524 X 2

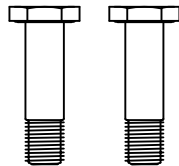

AN5-10a x 2

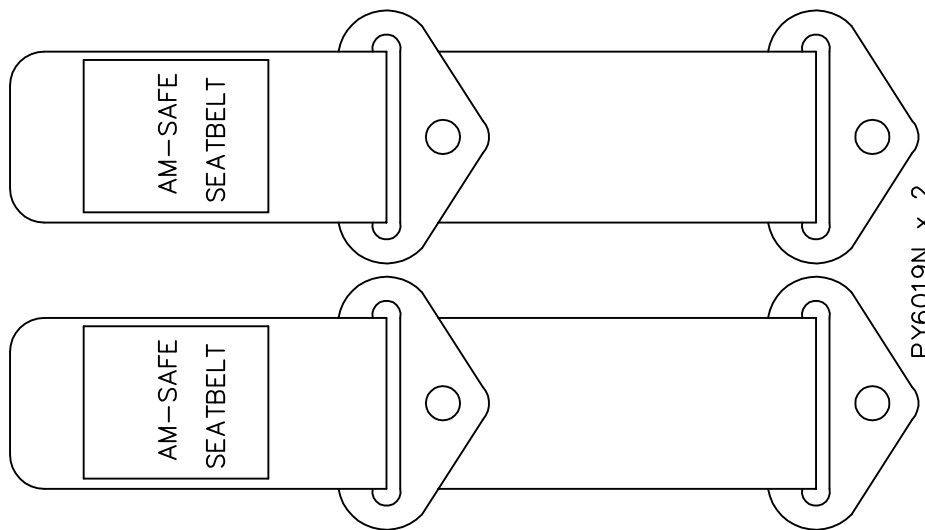

PY6019N x 2

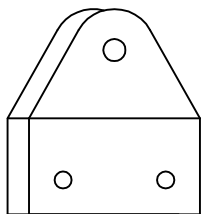

5001094 x 2

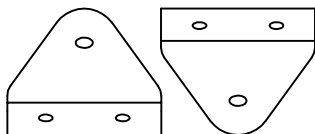

5000094 x 2

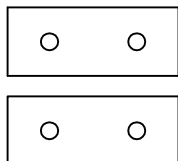

3128004 x 2

CARD T10-2: FIREWALL

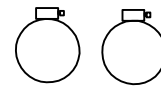

8-22 HOSE CLAMPS X 2



1A071BOD X 4

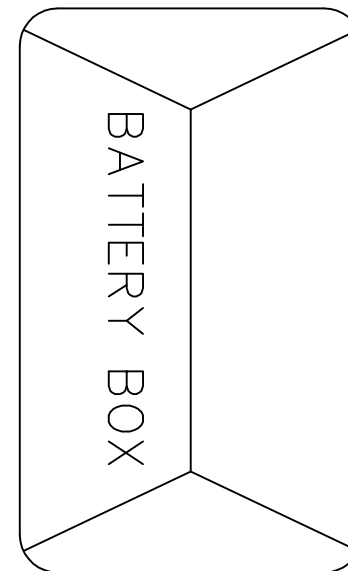

5040094 x 1



1042094 x 1

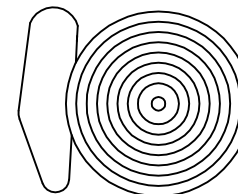

PH9916N x 1

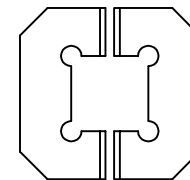

5037094 x 2

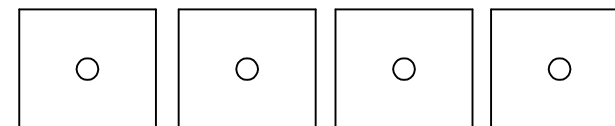

4025094 x 4

CARD T11-3: FUEL COMPONENTS CFI

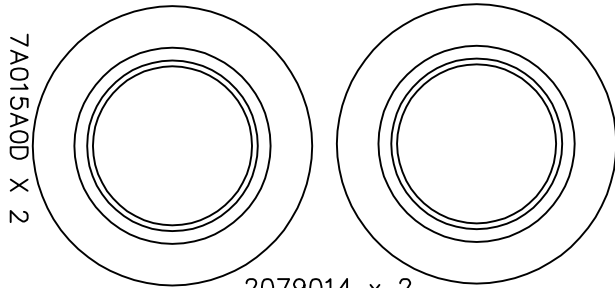

7A015A0D x 2

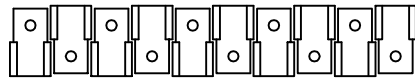

PH9992N x 10

PM0029N x 1

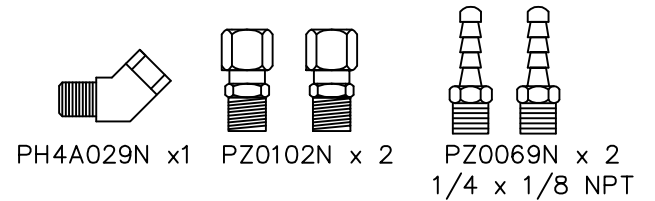

PH4A029N x1

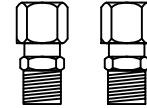

PZ0102N x 2

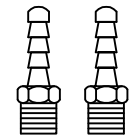

PZ0069N x 2
1/4 x 1/8 NPT

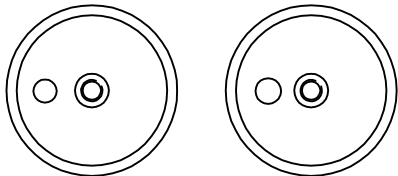

4A059B0D x 2, BS1806-224 (O-RING) x 2
4A059C0D x 2, 1/4 CAP SCREW UNC x 2
PG0158N (O-RING BS0014V) x 2



4A059D0D x 2

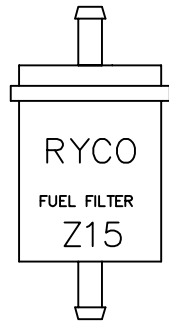

PM0009N x 1

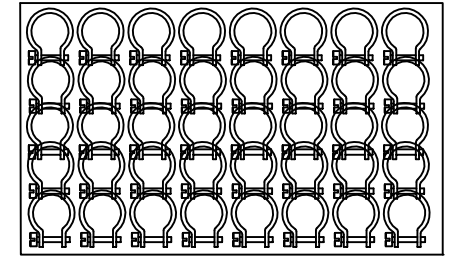
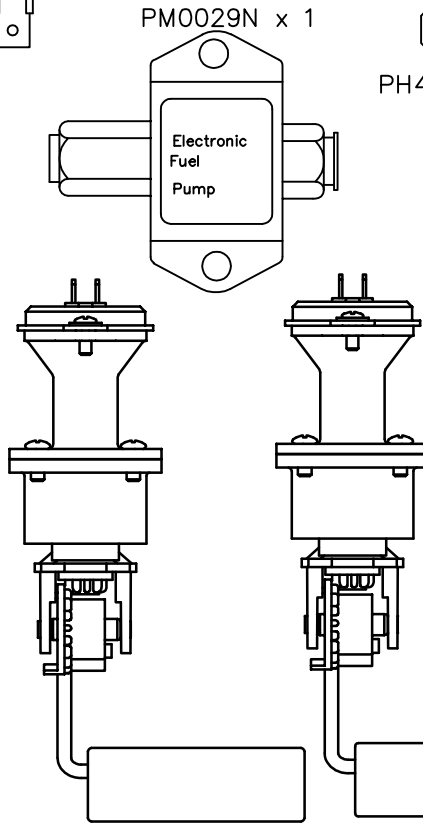

PV1252N x 40



PV4A001N x 4

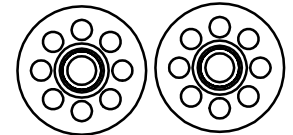

2080014 x 2



8G 3/4 PAN x 2

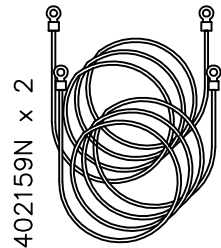

402159N x 2

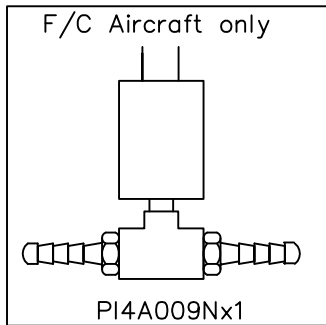

PI4A009N x 1

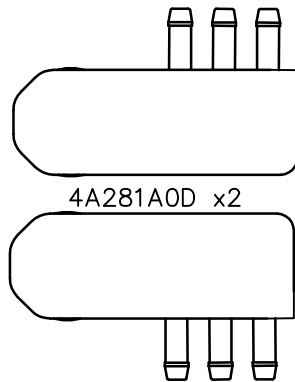

4A281A0D x 2

4A278A0D-1 x 2

3/16 ALLEN KEY x 1

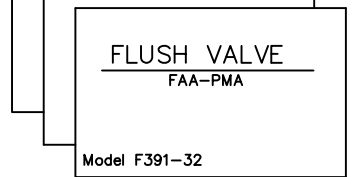

Model F391-32

PM0049N x 3



PE0222N x 5



4A120E0N x 1
Large Red
Lever & Tap
Assy

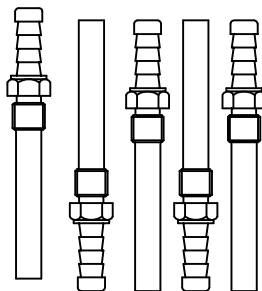

4001494 x 5

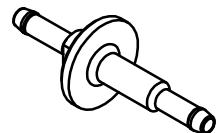

4A295B0D BULKHEAD X1

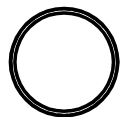

4A281C0D SLEEVE X1

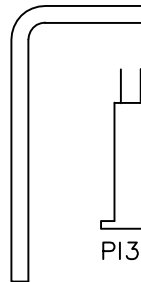

MS20365-624

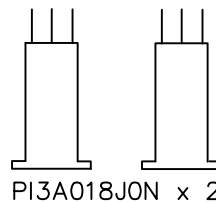

PI3A018J0N x 2

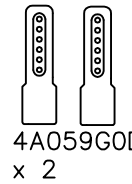

4A059G0D x 2

PH4A025N x 2

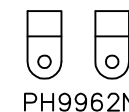

PH9962N x 2

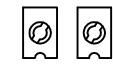

PH9952N x 2

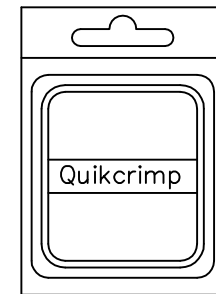

PHQK2N x 1

Electrical Connector

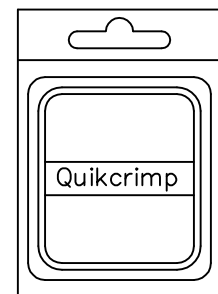

PHQK4N x 1

Electrical Connector

CARD T12-2: FUSELAGE TRIMMINGS

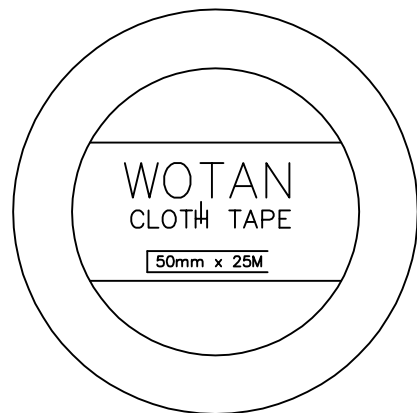

2003093 x 1

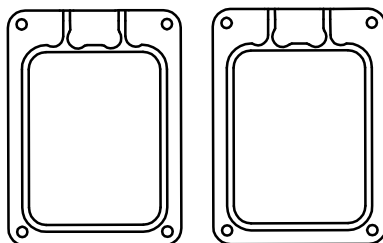

3A069B0D X 2

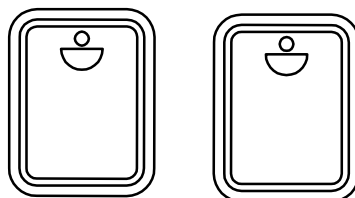

3A069C0D X 2

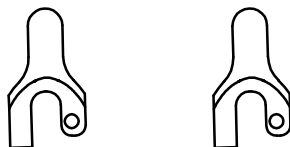

3A069D0D X 2

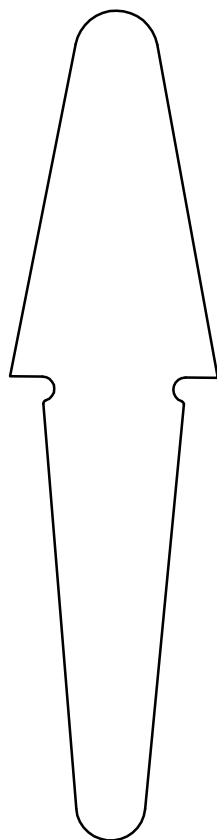

1A084B0D X 1

HARDWARE
M4 NYLOC NUT X 2
M4 x 25Pan X 2 SCREW
PH9H006 X 2 SCREWS

CARD J|T 13-2: COWL COMPONENTS

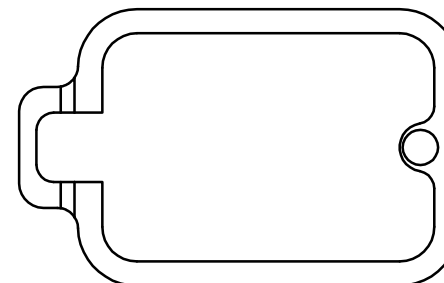

1A081B0D X 1

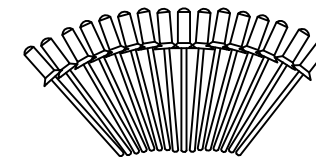

RIVETS TAPK
3-3 x 30
PH9929N

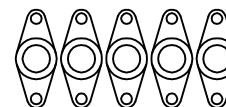

212-12D x 5



2600-6 x 2



2600-8x 3

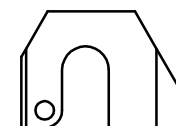

1A081E0D X 1

HARDWARE
PM5A003N X 1 MAGNET
PH9H006 X 2 SCREWS
COTTER PIN X 1

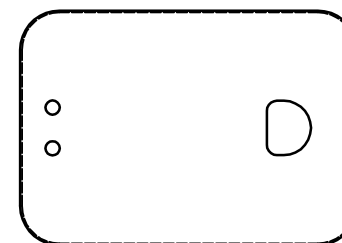

1A081D0D X 1

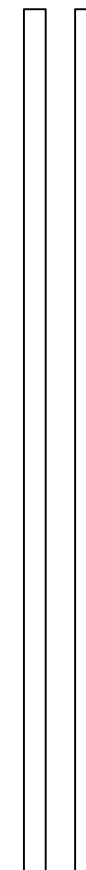

1/4" ALUMINIUM TUBE
x 2 (28cm)

Card JIT 14-2: OPTION 1 & 2 HARDWARE CFI

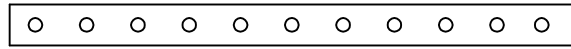

5019094 x 1

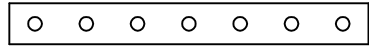

502009N x 1

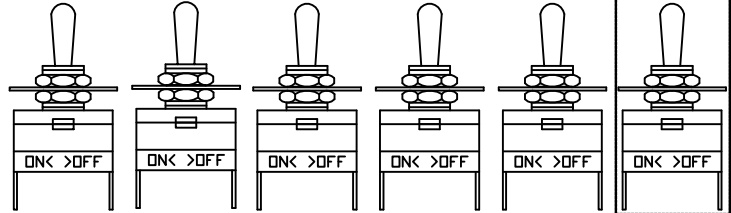

PI0316N x 5

optional

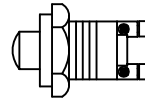

PI3A005A0N X 1
LED PANEL GREEN

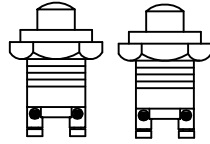

PI3A004A0N X 2
LED PANEL RED

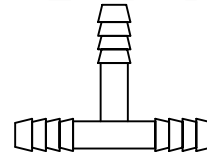

PI0170N x 1
PI0169N x 1
(ALT)

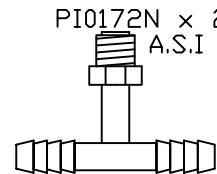

PI0172N x 2
A.S.I

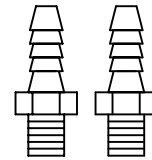

PI0171N x 1
(ALT)

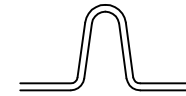

PV4A003N X 1

DESCRIPTION	QTY
AN960-10-Full Washer	13
PI3A019A0N Isolators	2
MS21069-L08 RETAINERS	8
MS21045-3	5
PH3A009N M3 X 8 PAN	10
AN3 12A	5
MS35206-245	8
TAPK 3-3 Rivet	16
MS21044B06 Campuss Nut	8
5/32 BRASS WASHER	3
5105004threaded washer	5
PH0419N M4x12PH Screw	30
M4 NYLON NUTS	30
MS35214-30Black Screws	17
MS3373-16C Alien Nut	14
PW0058N Grommet	5
MS35214-26Black Screws	30

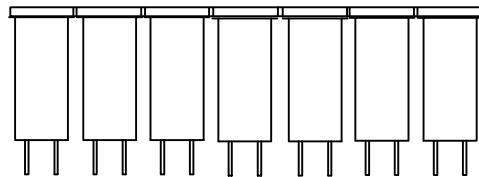

15A Circuit Breaker x1
10A Circuit Breaker x2
5A Circuit Breaker x4

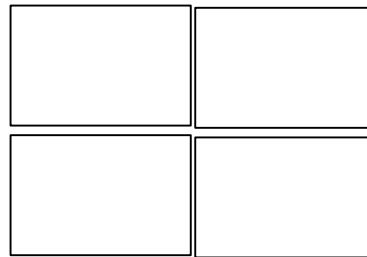

PI4A01N x 2
Suppressor

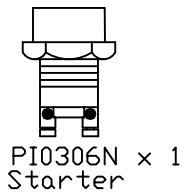
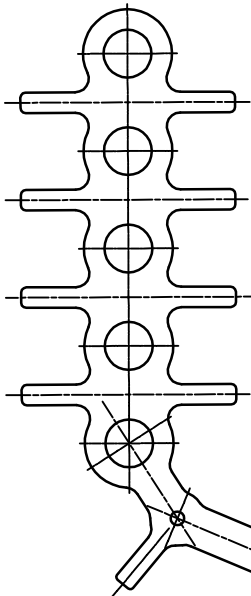

PI0306N x 1
Starter

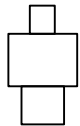

Female BNCx1
2164514 crimp
type

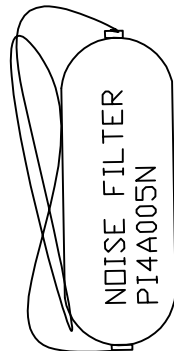

NOISE FILTER
PI4A005N

Electrical List:

- Red Spade Female X 110
- Blue Spade Female X 12
- Yellow Spade Female X 16
- Red Spade Male X 10
- Red Ring 4mm X 20
- Red Ring 6mm X 4
- Blue Ring 4mm x 3
- Blue Ring 5mm X 2
- Blue Ring 8mm X 1
- Yellow Ring 5mm X 7
- Yellow Ring 6mm X 5
- Yellow Ring 8mm X 5

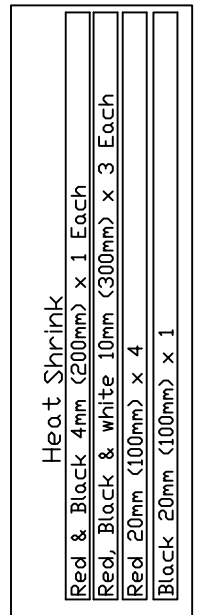
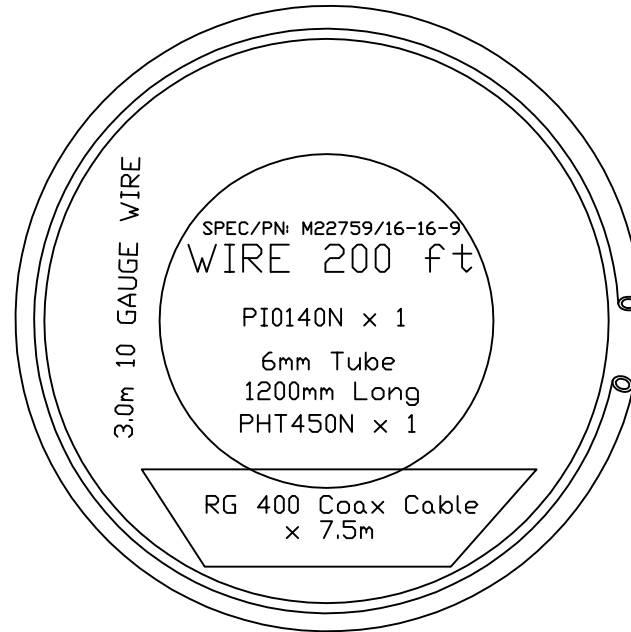

5A020E0D X 1

Card J1T 14-3: OPTION 3&4 HARDWARE

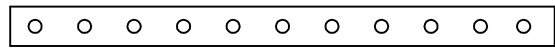

5019094 x 1

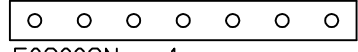

502009N x 1

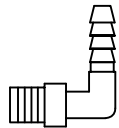

PI0316N x 8 (ALT)

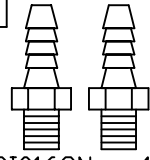

PI0169N x 1 (ALT)

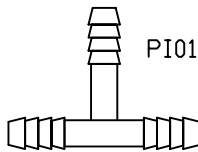

PI0170N x 1 optional

PI0171N x 2 A.S.I

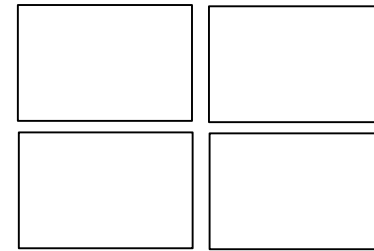
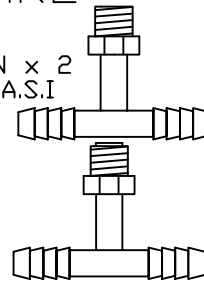

PI4A010N x 2 Suppressor

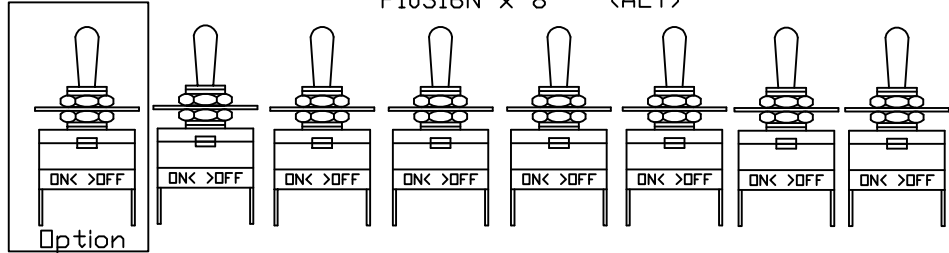

Option

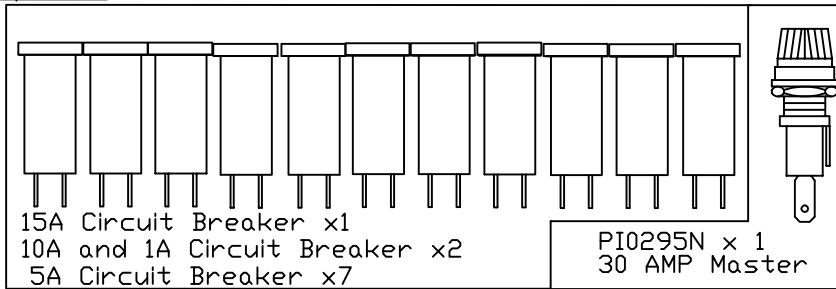

15A Circuit Breaker x1
10A and 1A Circuit Breaker x2
5A Circuit Breaker x7

PI0295N x 1
30 AMP Master

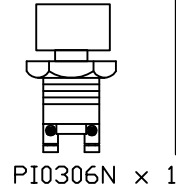

PI0306N x 1

Electrical List:

- Red Spade Female X 110
- Blue Spade Female X 12
- Yellow Spade Female X 16
- Red Bullet Male X 1
- Red Spade Male X 10
- Red Ring 4mm X 20
- Red Ring 6mm X 4
- Blue Ring 4mm x 3
- Blue Ring 5mm X 2
- Blue Ring 8mm X 1
- Yellow Ring 5mm X 7
- Yellow Ring 6mm X 5
- Yellow Ring 8mm X 5

DESCRIPTION	QTY
PW0058N Grommets	7
AN960-10-Full Washer	13
PI3A019A0N	2
MS21069-L08 RETAINERS	8
MS21045-3	7
5105004 Threaded Washer	7
AN3_12A	7
MS35206-245	8
MS35214-29	3
MS21044B06	3
5/32 BRASS WASHER	3
TAPK 3-3	16
M4 x 12 PH	30
M4 NYLOC NUTS	30
MS35214-31 Screws	14
MS3373-16C Nuts	14
PH3A009N M3 X 8 PAN	10

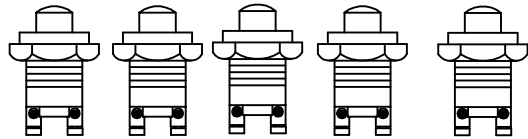

PI3A004A0N X 4
LED PANEL RED

PI3A005A0N X 1
LED PANEL GREEN

Female BNCx1
2164514 crimp
type

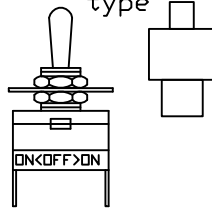

Landing Light
switch(NVFR)

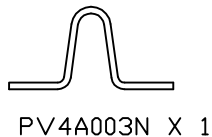

PV4A003N X 1

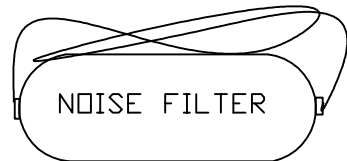

NOISE FILTER

5A043H0D - 3PIECE
BUS BAR

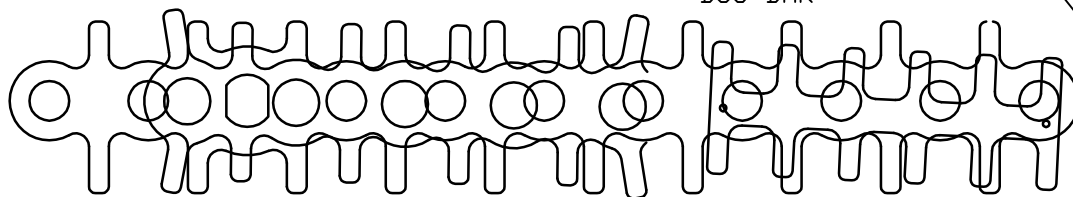

SPEC/PN: M22759/16-16-9

CUST PN: 16-16Wire

3.0m 10 GAUGE WIRE

WIRE 300ft

PI0140N x 1

6mm Tube
1200mm Long
PHT450N x 1

RG 400 Coax Cable
x 7.5m

Heat Shrink

- Red & Black 4mm (200mm) x 1 Each
- Red, Black & white 10mm (300mm) x 3 Each
- Red 20mm (100mm) x 4
- Black 20mm (100mm) x 1

Note - Please make sure the longer Throttle push rod is been supplied on throttle card.

Card JIT 14-3: OPTION 5 HARDWARE

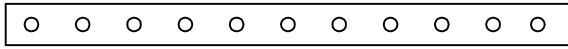

5019094 x 1

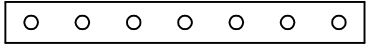

502009N x 1

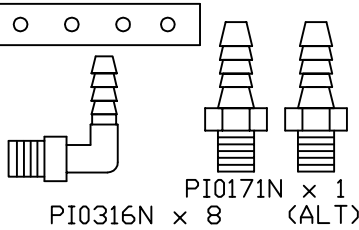

PI0316N x 8
PI0171N x 1 (ALT)

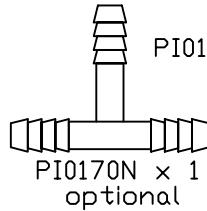

PI0170N x 1
optional

PI0172N x 2
A.S.I

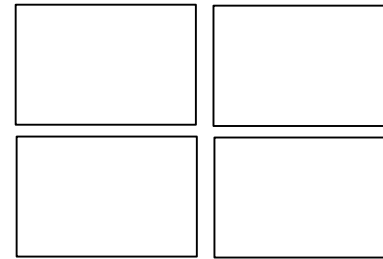
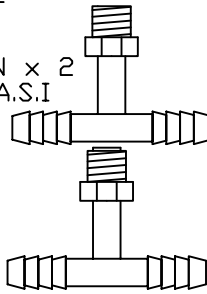

PI4A010N x 2
Suppressor

INSTRUMENT DIMMER
COMPONENTS PACK

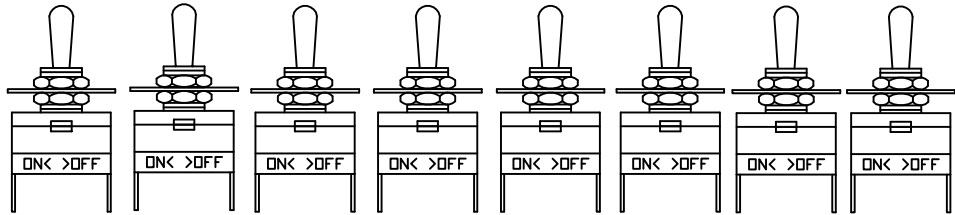

Electrical List:

- Red Spade Female X 110
- Blue Spade Female X 12
- Yellow Spade Female X 16
- Red Bullet Male X 1
- Red Spade Male X 10
- Red Ring 4mm X 20
- Red Ring 6mm X 4
- Blue Ring 4mm X 3
- Blue Ring 5mm X 2
- Blue Ring 8mm X 1
- Yellow Ring 5mm X 7
- Yellow Ring 6mm X 5
- Yellow Ring 8mm X 5

DESCRIPTION	QTY
PW0058N Grommets	7
AN960-10-Full Washer	13
PI3A019A0N ISOLATORS	2
MS21069-L08 RETAINERS	8
MS21045-3 HEAT NUTS	7
5105004 Threaded Washer	7
AN3 12A	7
MS35206-245 SCREWS	8
MS35214-29	3
MS21044B06	3
5/32 BRASS WASHER	3
TAPK 3-3	16
M4 x 12 PH	30
M4 NYLOC NUTS	30
MS35214-31 Screws	14
MS3373-16CNuts	14
PH3A009N M3 X 8 PAN	10

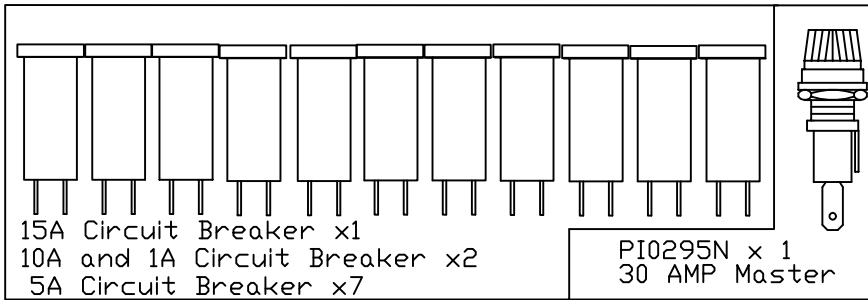

15A Circuit Breaker x1
10A and 1A Circuit Breaker x2
5A Circuit Breaker x7

PI0295N x 1
30 AMP Master

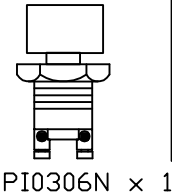

PI0306N x 1

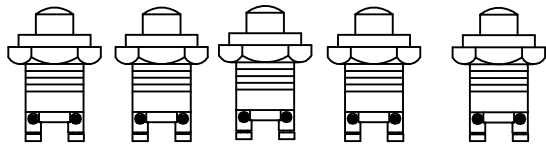

PI3A004A0N X 4
LED PANEL RED

PI3A005A0N X 1
LED PANEL GREEN

Female BNCx1
2164514 crimp
type

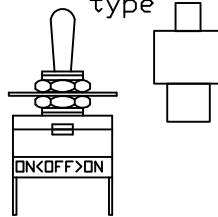

Landing Light
switch (NVFR)

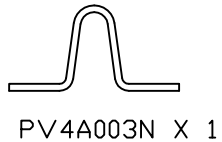

PV4A003N X 1

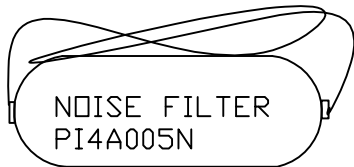

NOISE FILTER
PI4A005N

5A043H0D - 3PIECE
BUS BAR

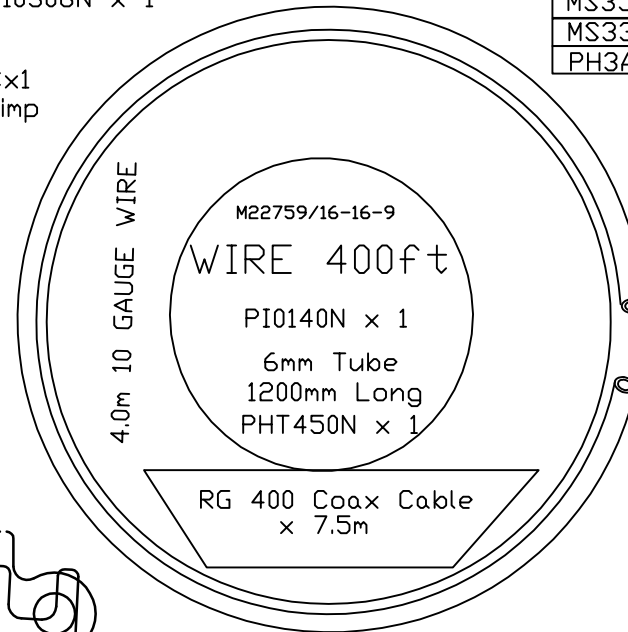

4.0m 10 GAUGE WIRE

M22759/16-16-9
WIRE 400ft
PI0140N x 1
6mm Tube
1200mm Long
PHT450N x 1
RG 400 Coax Cable
x 7.5m

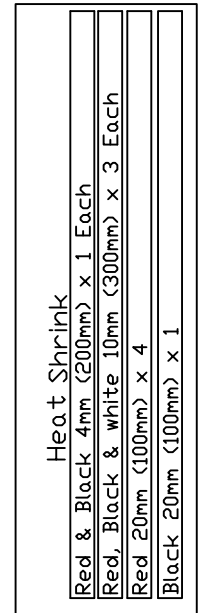

Heat Shrink
Red & Black 4mm (200mm) x 1 Each
Red, Black & white 10mm (300mm) x 3 Each
Red 20mm (100mm) x 4
Black 20mm (100mm) x 1

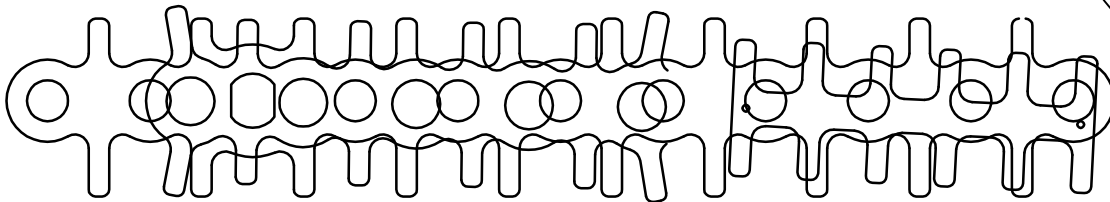

CARD T15B-2: SPARES CFI

- Bundy Tube 1 to 6mm x 1
- Bundy Tube 8mm x 10
- Bundy Tube 10mm x 4
- Bundy Tube 12mm x 2
- Bundy Tube 17mm x 2

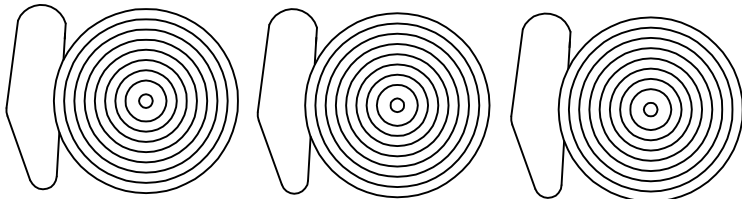

PH9916N x 3

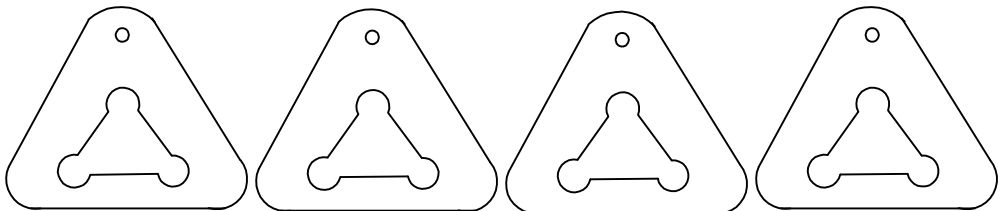

401009N x 4

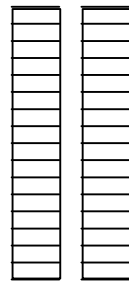

PH4A032N X 2
SPRINGS

Bullet Terminal x 1



Cigarette
Lighter X 1

4MM CLEAR TUBE X 0.5M

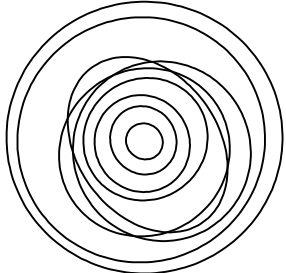

FUEL LINE SHEATING X 4.5

PI0149N x 1

Headset Hanger

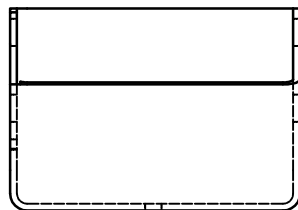

4984124 x 1
Drip Tray

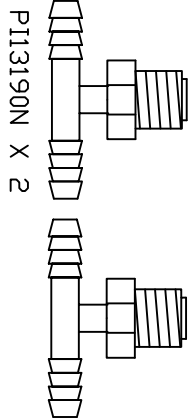

PI13190N X 2

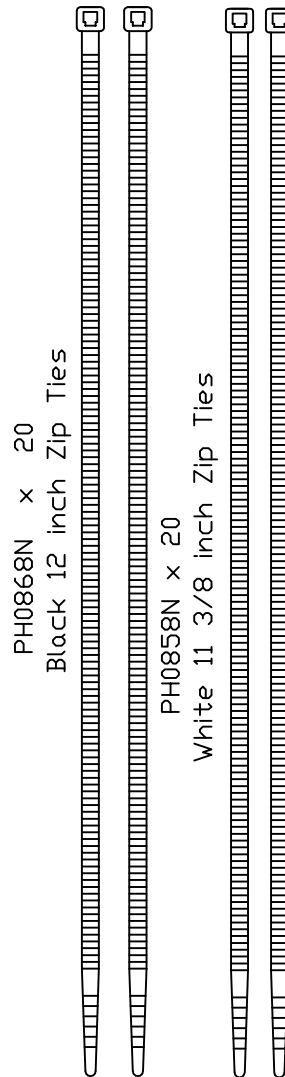

PH0868N x 20
Black 12 inch Zip Ties

PH0858N x 20
White 11 3/8 inch Zip Ties

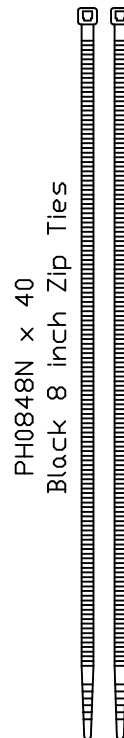

PH0848N x 40
Black 8 inch Zip Ties



PH0838N x 1 PACK
Black 4 inch Zip Ties

INSERTION RUBBER 120 X 300



MS35206-243 x 55
5/32 BRASS
WASHERS X 55
5A048A1D X 55
Screw Socket

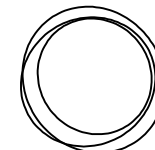

LOCK WIRE X3M
PH0828N



2A052A0D X 2



3A065A0D X 1

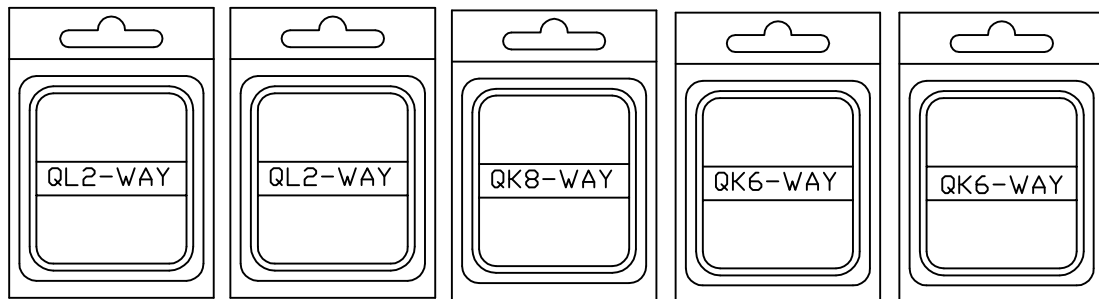

4615074 X 6

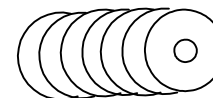

AN970-4 washers x 7

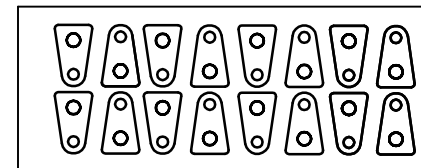

2001594 X 1

CARD T16-3 : ELECTRIC FLAPS



PB0009N x 4
3/16 ROD END

PB0112N x 1
1/4 ROD END

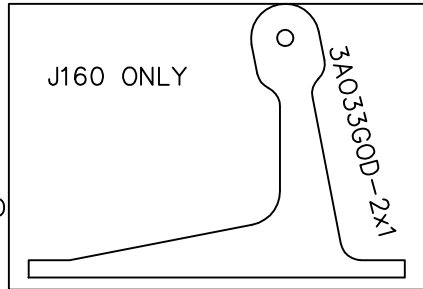

J160 ONLY

3A033G0D-2x1

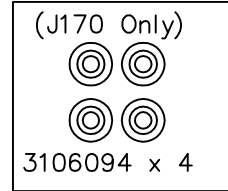

(J170 Only)

Nylon washer
x 6

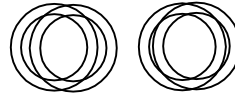

DESCRIPTION	QTY	DESCRIPTION	QTY
AN960-416L-Half Washer	4	AN3-13A-Bolts	3
AN960-416-Full Washer	5	MS20365-1032-Nut Nyloc	4
AN316-3-Half Nut	4	RING TERMINALS 4mm RED	2
AN960-10-Full Washer	8	AN3-6A-Bolts	2
AN960-10L-Half Washer	4	AN3-10A-Bolts	2
MS20365-428-Nut Nyloc	2	MALE SPADE TERMINAL RED	2
AN4-11A-Bolt	1	FEMALE SPADE TERMINAL RED	6
PH0239N (1/4 UNF Plain)	1	AN310C-3 Castle Nut 3/16	1
AN316-5R 5/16 HALF NUT	2	3000B94 Spacer Rod	3
AN3-16 M/16" BOLT DRLD	1	AN3-11A-Bolts	1
3A055HOD FLAP DRV MNT	1	PH9962N-P Clamp white	3
3A085BOD-SharpIndacater	1		
3A085COD-Indacaterwasher	1		

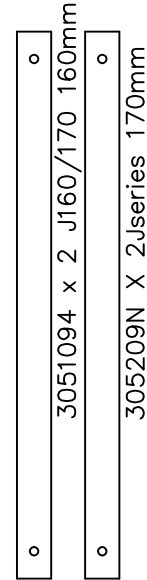

3051094 x 2 J160/170 160mm

305209N X 2Jseries 170mm

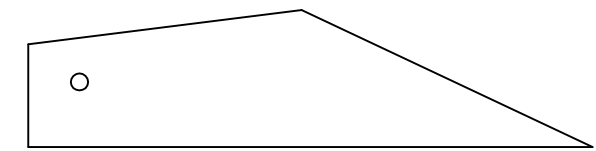
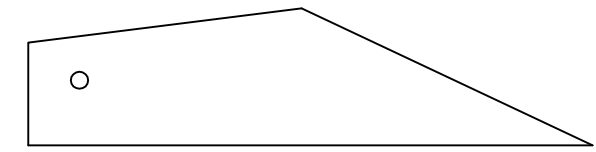
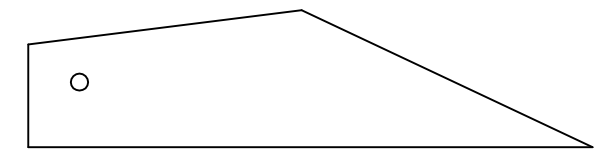
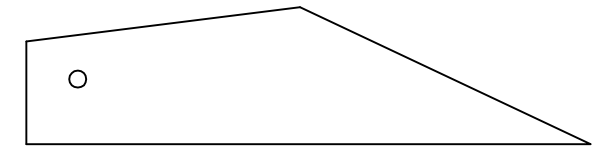
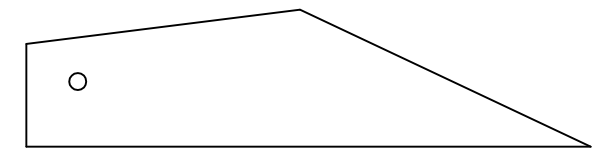

2026094 x 6

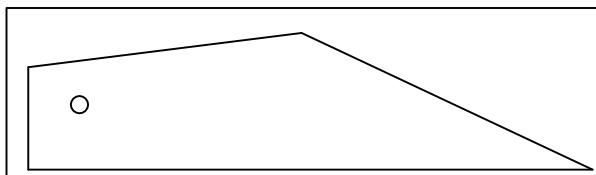
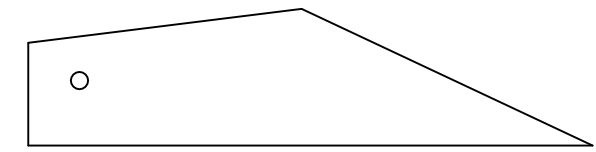

(J170 Only)

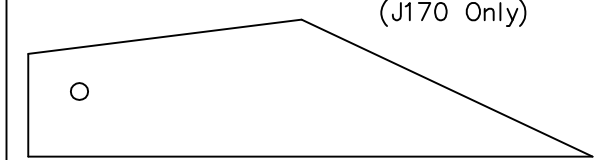

2026094 x 2

PC3A002 (Choke Cable
Inner and outer)x1

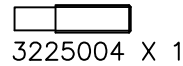

3225004 X 1

3A062B0D-2
X1

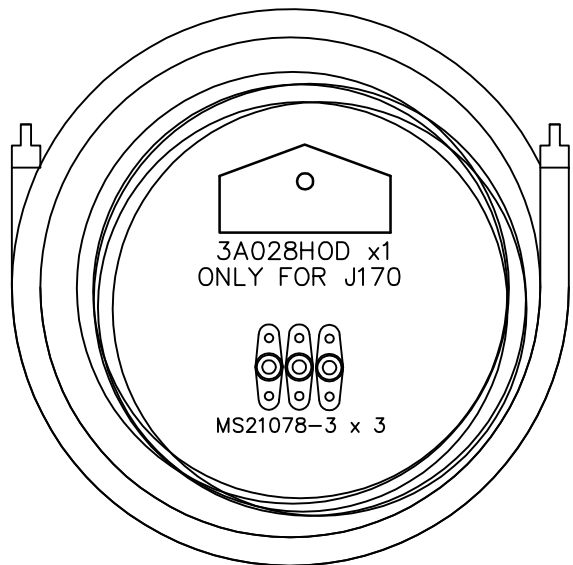
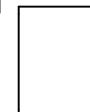

3A028HOD x1
ONLY FOR J170

MS21078-3 x 3

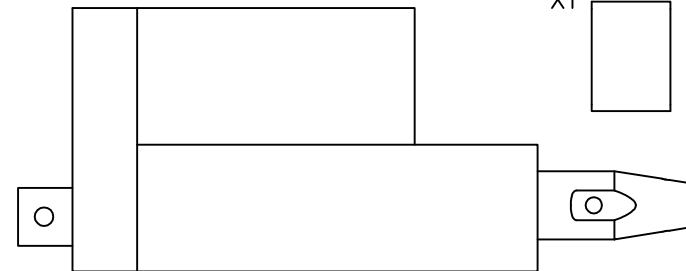

PM3A000N x 1 (ELECTRIC FLAP DRIVE)

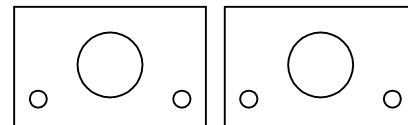

3003394 x 2

PI3A003A0N-1x1

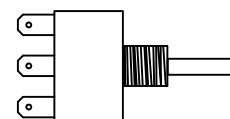

CARD JT 17B-2: ELEVATOR SYSTEM AND CONTROL STICK CFI

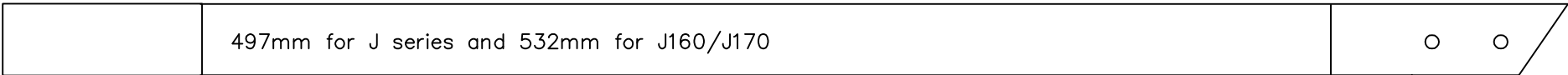

497mm for J series and 532mm for J160/J170

J SERIES 3A093BOD X 1 T SERIES 3A081BOD X 1

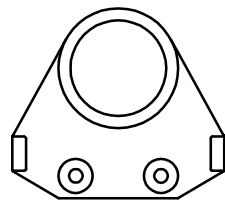
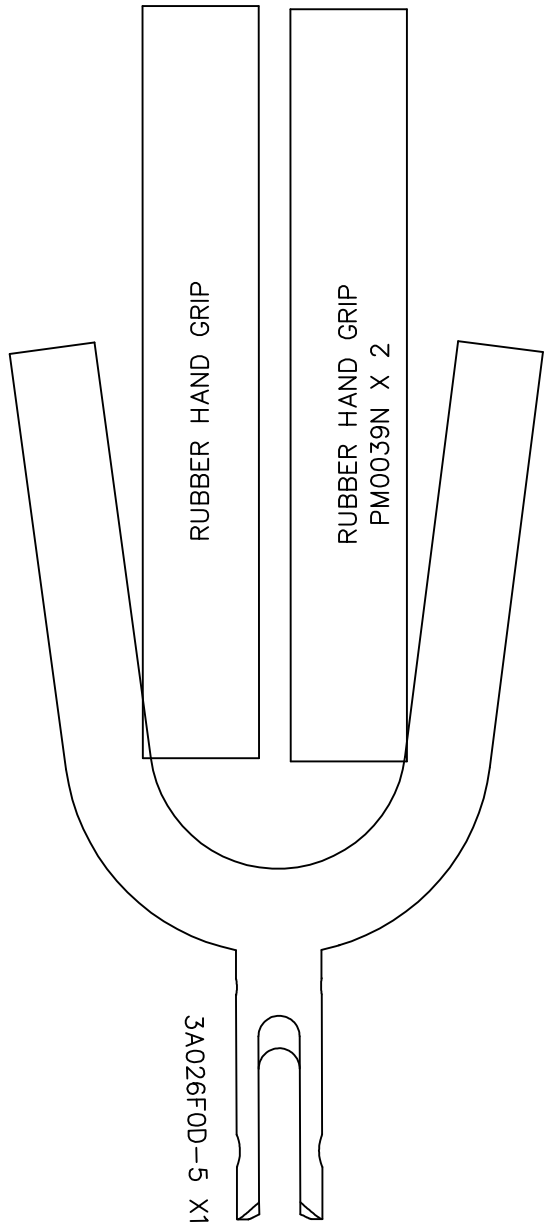

3A087BOD X 1

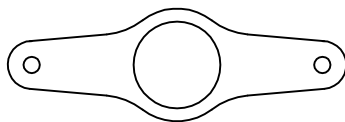

3A087DOD X 1



3/16 x 3/4 UNC
CAP SCREW

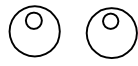

3A087COD X 2

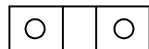

3224004-1 x 1

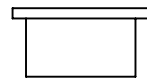

1007094 x 1

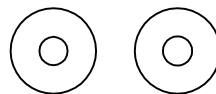

3109194 x 2
NYLON WASHERS 5/16"

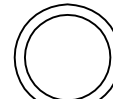

PB3A003N x 1

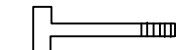

AN3-23A X 1

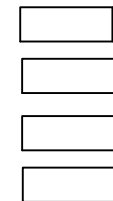

3000C84 x 4
(Control Bush)

3000B94 x 1



Spiral Wrap x 150mm

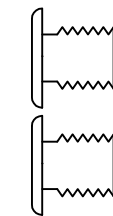

PM0040N x 2

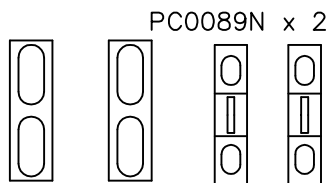

PC0089N x 2

PC0099N x 2

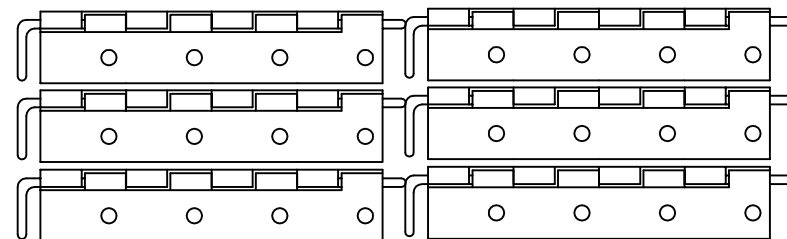

2001G94 x 6 STEEL J SERIES & J170'S
2001G94 x 4 STEEL J160'S

CARD T19-3 : NOSELEG current as on 24-4-09

DESCRIPTIONS:	QTY:
1 AN5-43 BOLT	1
2 AN5-15A BOLT	1
3 AN3-7A BOLT	1
4 AN3-6A BOLT	1
5 AN3-22A BOLT	3
6 AN310-5 NUT	1
7 MS20365-1032 NUT	4
8 AN960-1032 WASHER	3
9 AN960-516 WASHER	6
10 AN380-2-2 SPLIT PIN	1
11 MS20365-428 NUT	2
12 MS20365-524 NUT	1
13 AN960-416 WASHER	2
14 AN4-16A BOLT	1
15 AN970-4	1

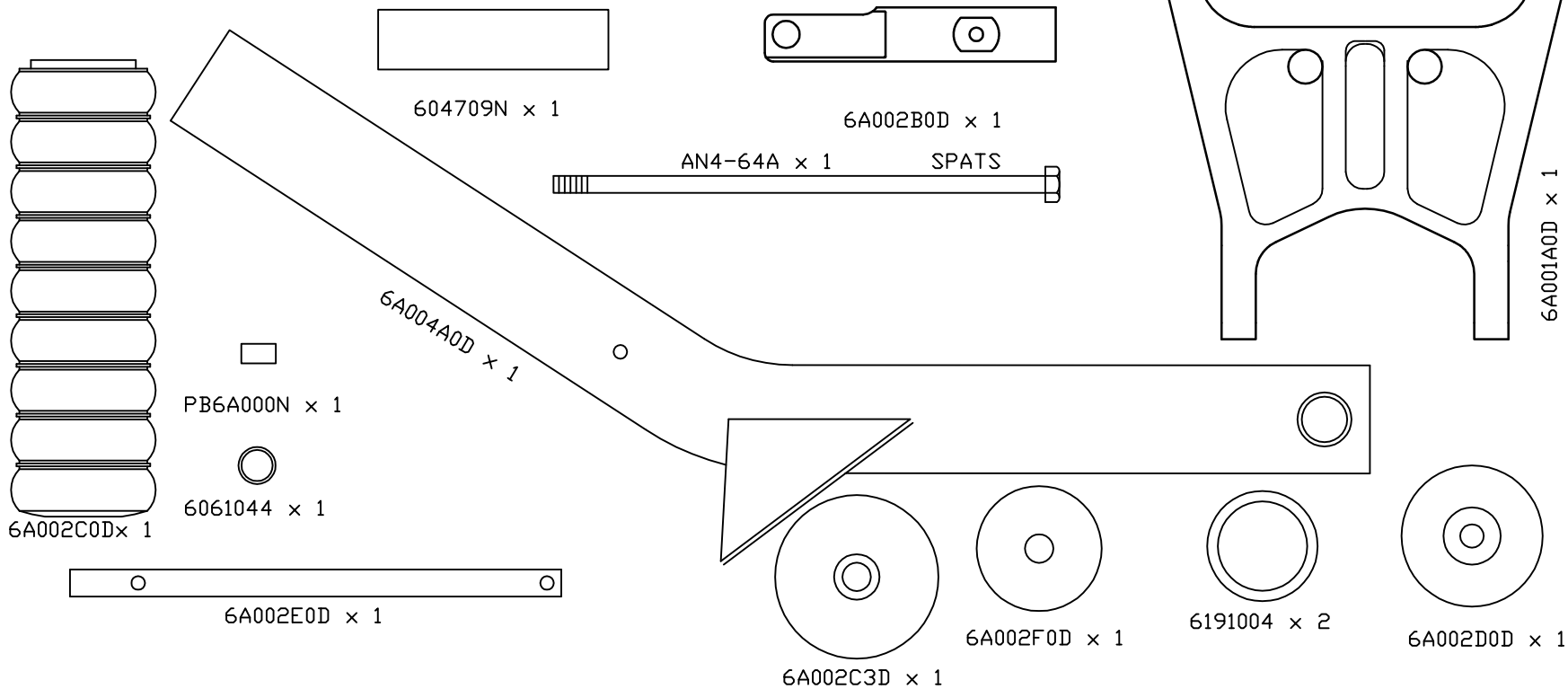
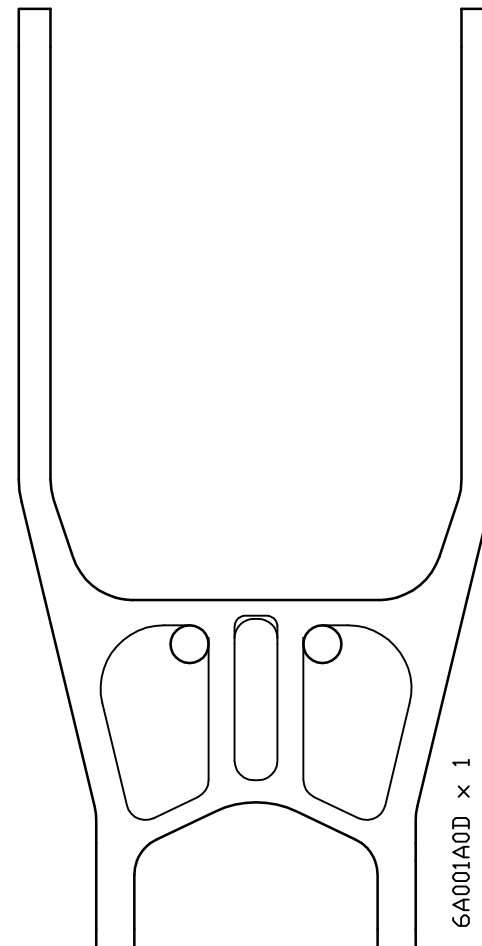
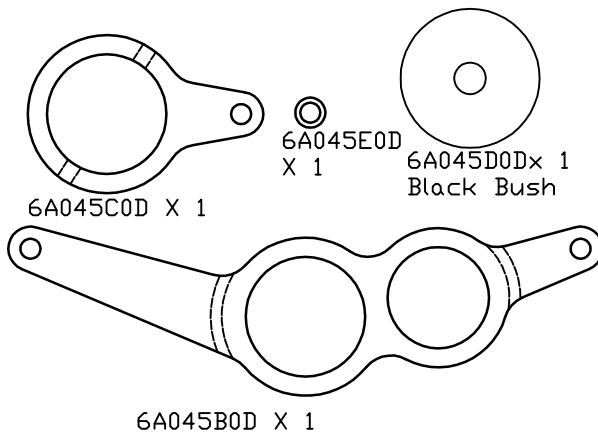

CARD **J|T** 20: NOSEWHEEL

6213123-1 x 1

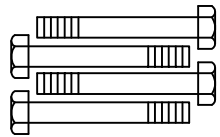

AN4-11A x 4

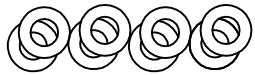

AN960-416 x 8

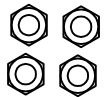

MS20365-428x 4



AXLE

6065044 x 1

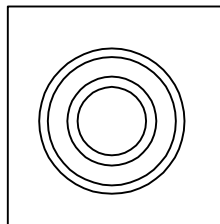

PB0029N x 2
BEARINGS

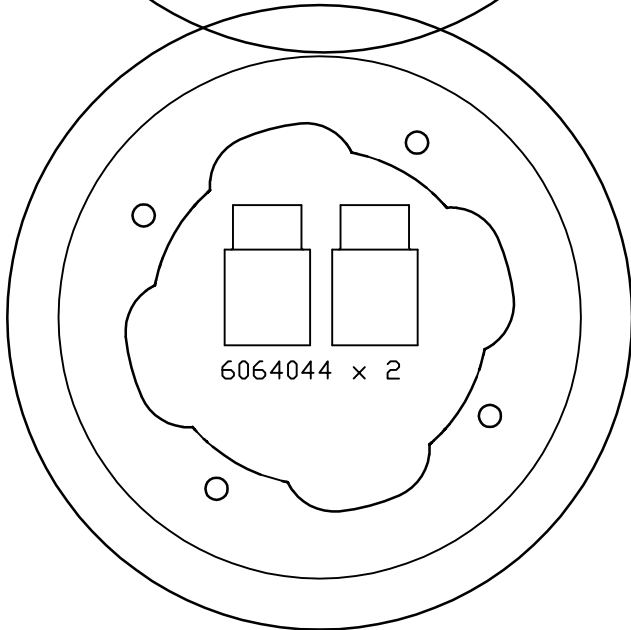
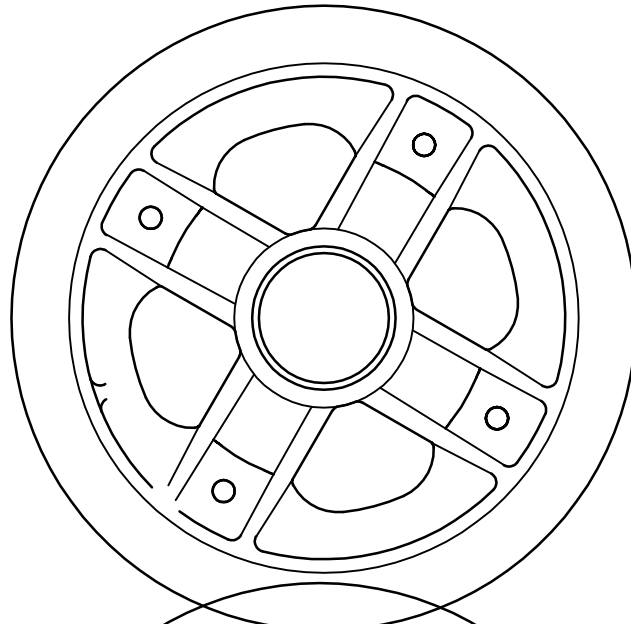

6211023-2 x 1

CARD **J|T** 20: NOSEWHEEL

6211023-2 x 1

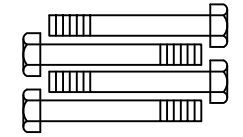

AN4-11A x 4

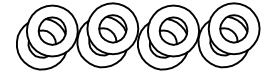

AN960-416 x 8

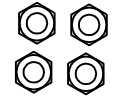

MS20365-428x 4



AXLE

6065044 x 1

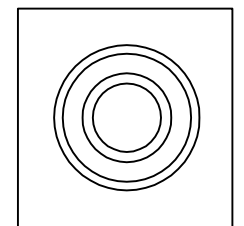

PB0029N x 2
BEARINGS

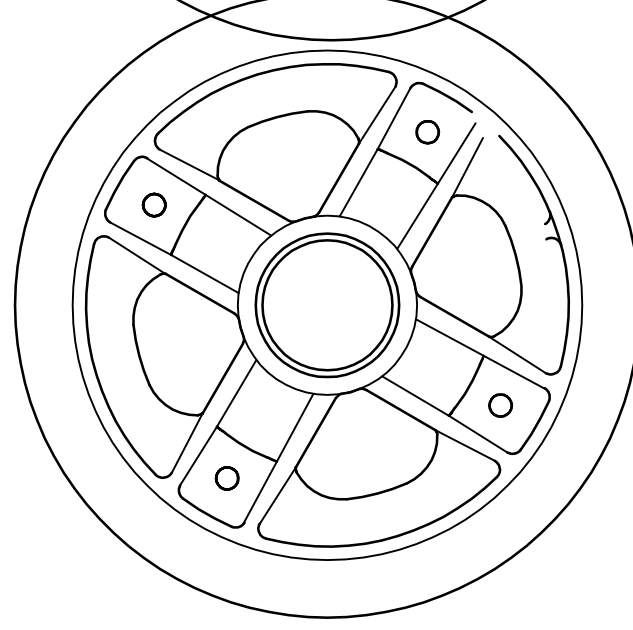
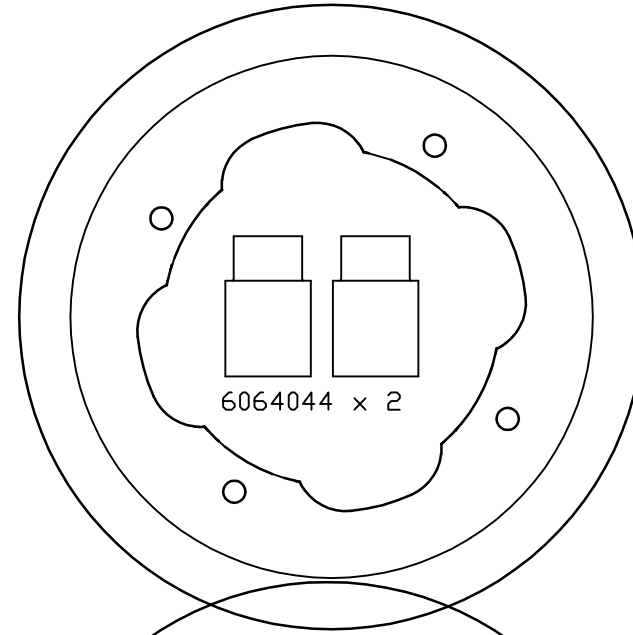

6213123-1 x 1

CARD J | T 21-2: MAIN WHEELS

PW0009N x 3
1 1/8 Grommet

6211023-2 x 1

6210023-2 x 1

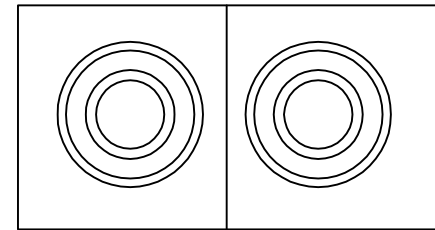

PB0029N x 4 (BEARINGS)

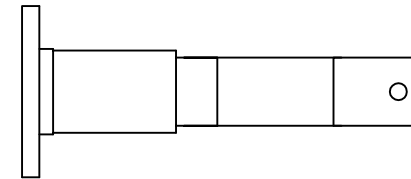

6A028B0D x 2

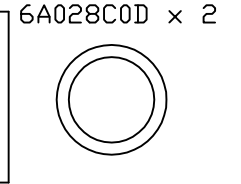

6A028C0D x 2

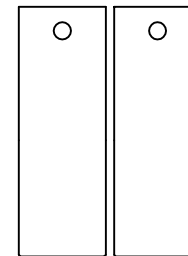

6000594 x 2

HD STUB AXLES

	DESCRIPTIONS:	QTY:
1	AN4-11A BOLT	8
2	MS20365-428 NUT	8
3	AN960-416 WASHER	16
4	AN5-15A BOLT	4
5	AN5-16A BOLT	4
6	AN960-516 WASHER	22
7	MS20365-524 NUT	8
8	MS21047-3	8
9	A3235-020-935	8
10	MS246935273	8
11	AN4-4A	2
12	AN960-416L	4
13	MS24693C47	10

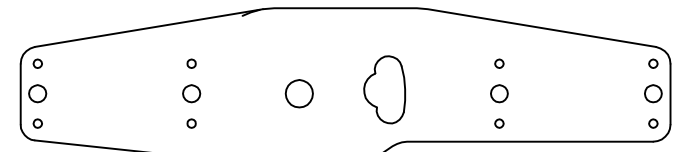

6A039A0D x 2

6210023-2 x 1

6211023-2 x 1

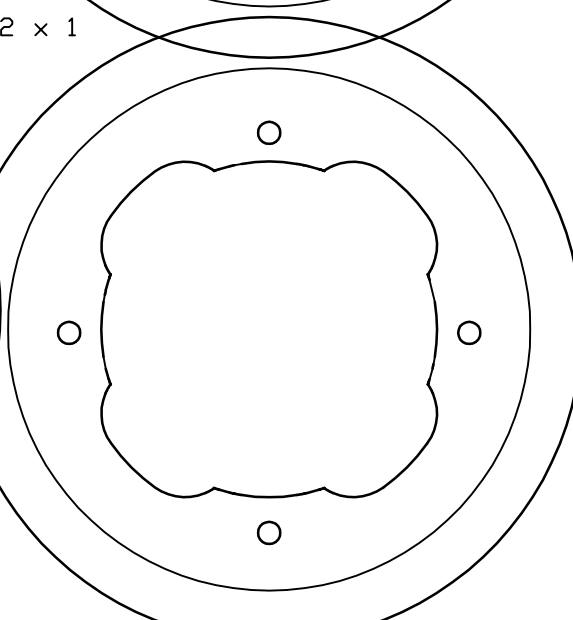
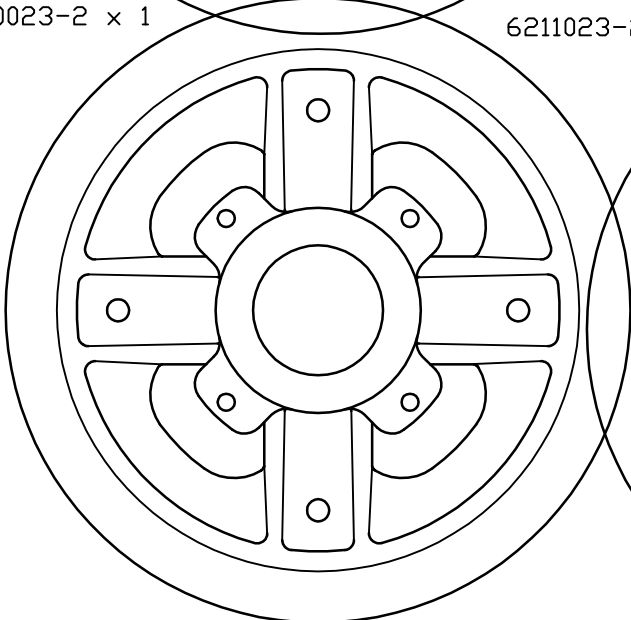
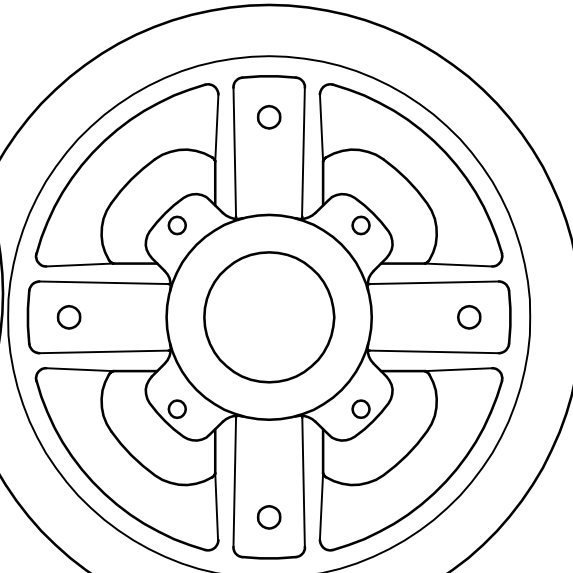
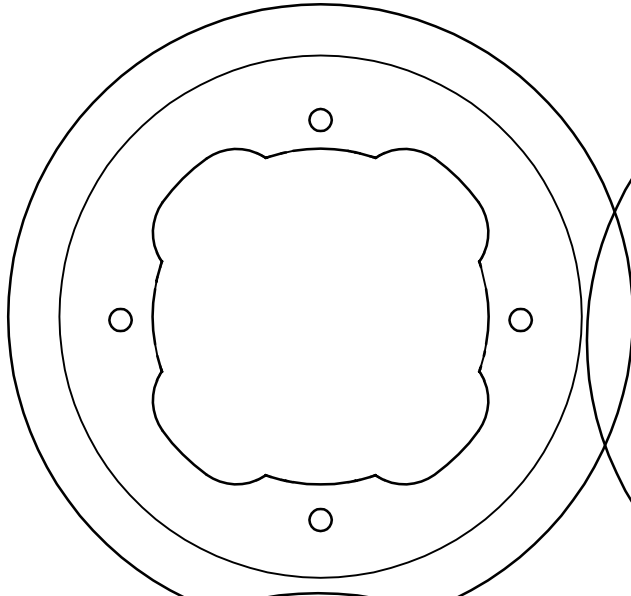

HOT AIR MIXER BOX COMPONENTS CARD JIT 22-2:

A- AE102/624- AS1072- 8 FIRESLEEVE

PQ0019N x 1 x 700

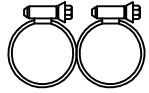

PV4A001N x 2

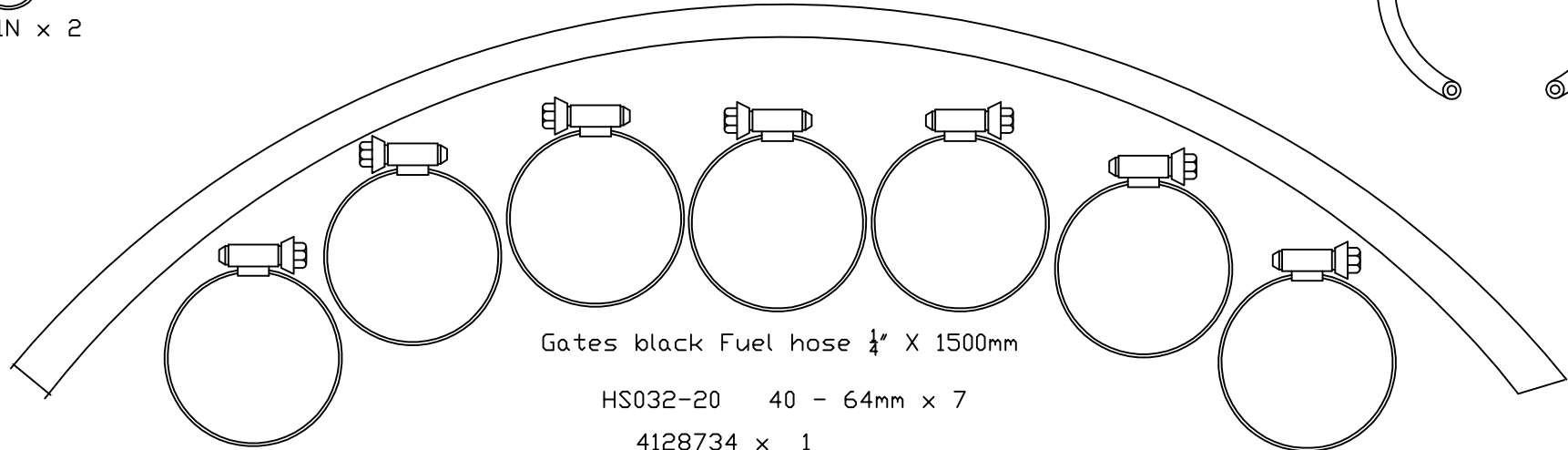
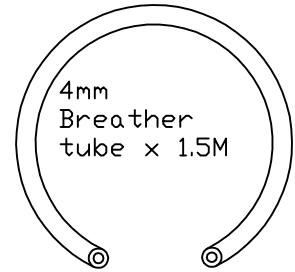

Gates black Fuel hose $\frac{1}{4}$ " X 1500mm

HS032-20 40 - 64mm x 7

4128734 x 1

2.25" SCATHOSE 1.4m

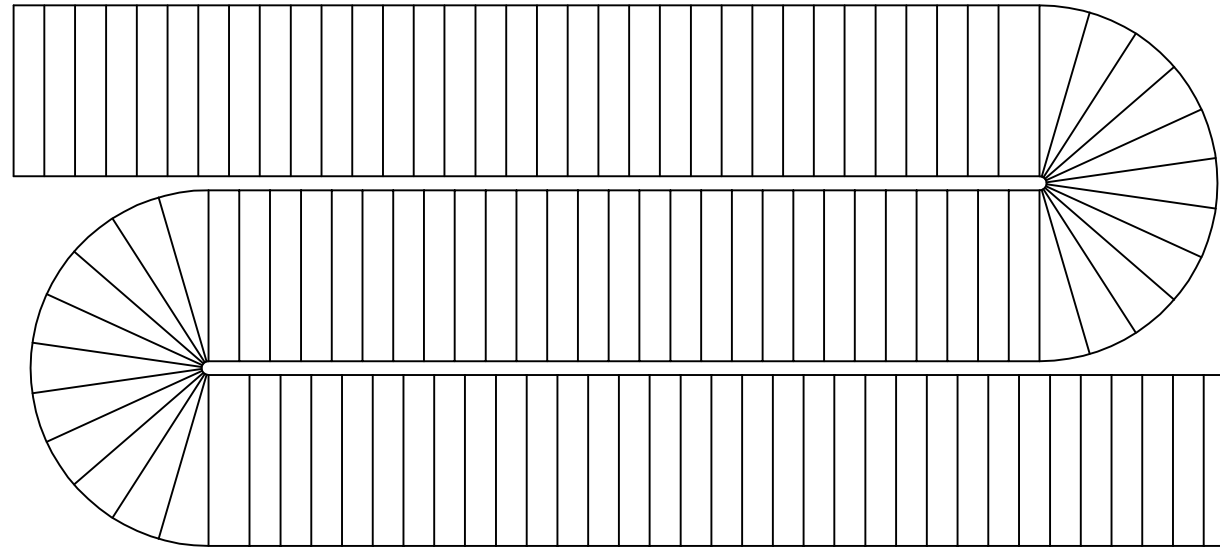

CARDJT 23-2: OIL BOTTLE, ENGINE, SPINNER HARDWARE

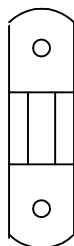
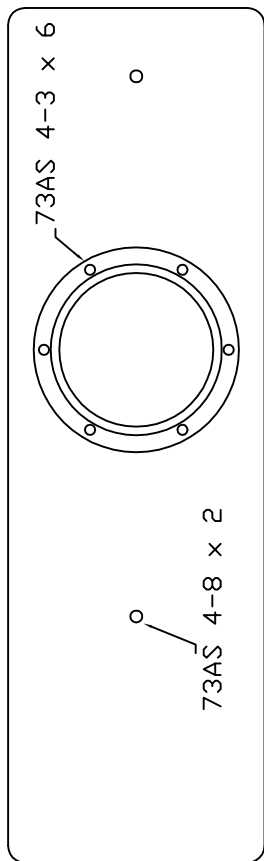

PV0040N x 1
HOSE SADDLE

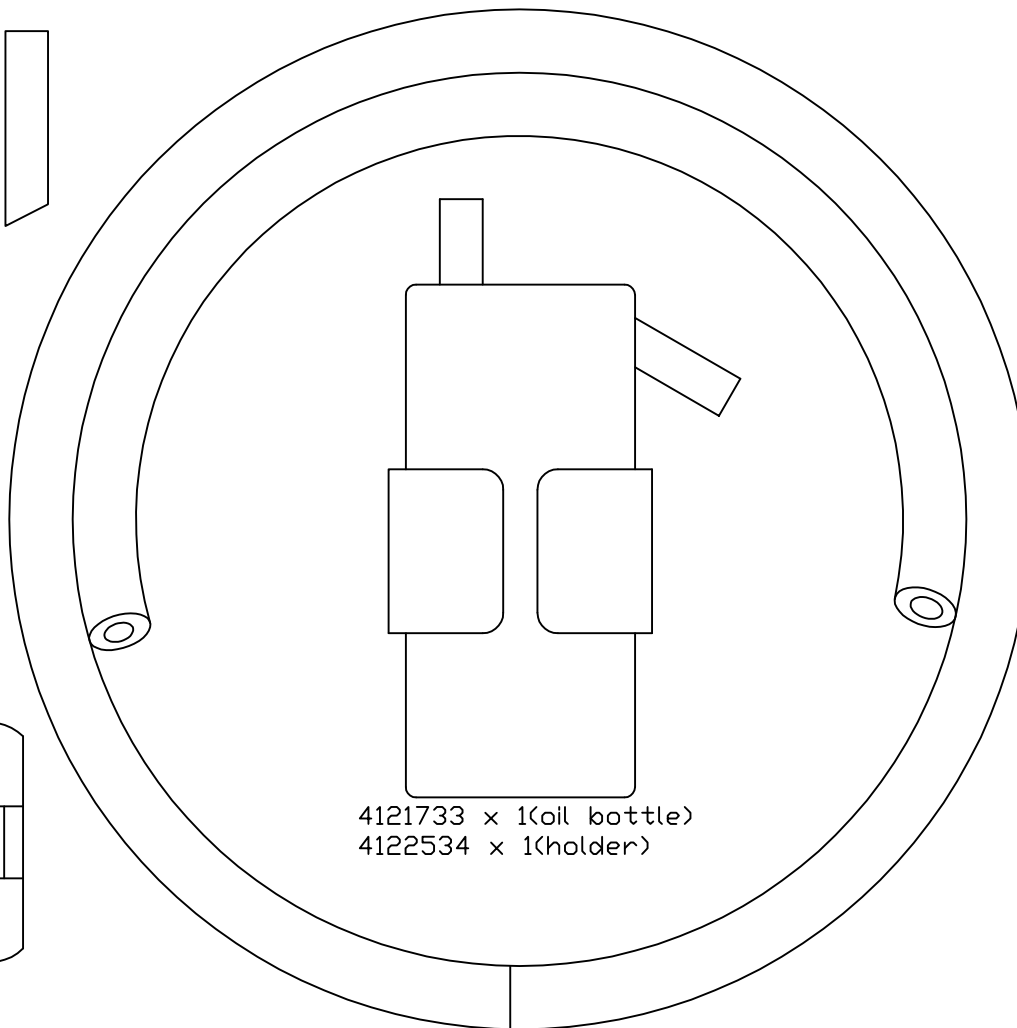

412365N x 1
1/2 inch Heater Hose (1400mm)

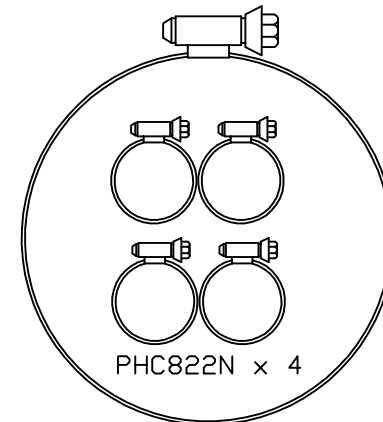

6 Cyl HS060 105-130mm x 2
4 Cyl PHC8408 x 2

8G x 1/2 P/H



8G x 1/2 CSK x2

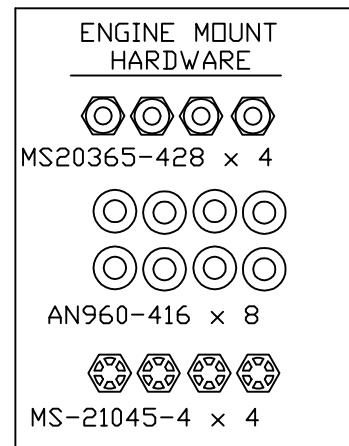
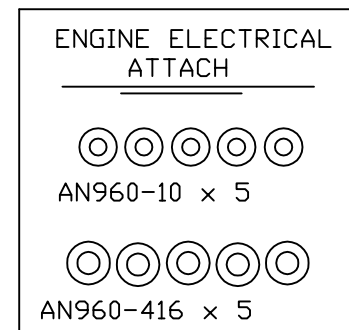

CARD T 24: OIL COOLER

STRATOFLEX 2650 – 0 10

PH4A013N x 1 (900mm)

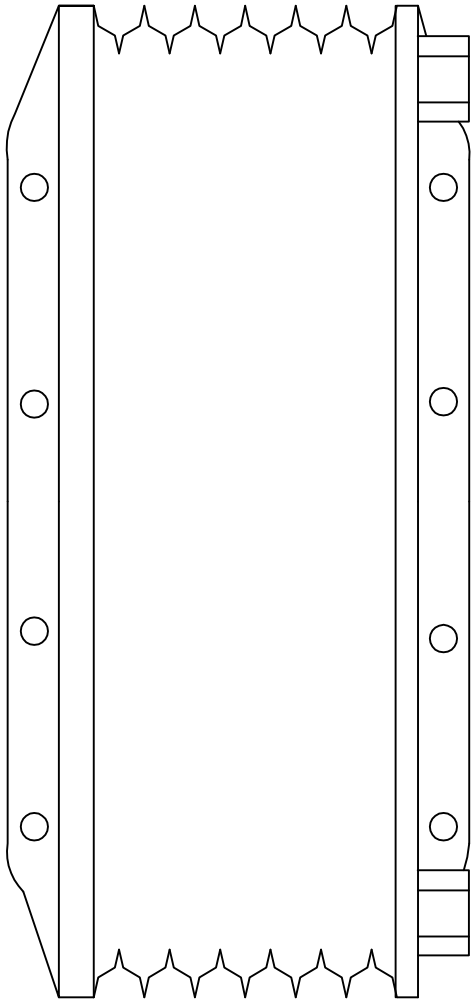

PH4A015N x 1

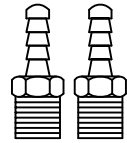

BP30608
3/8 x 1/2
Male Tail x
2



PH0828N x 1
Lockwire 4 Meter

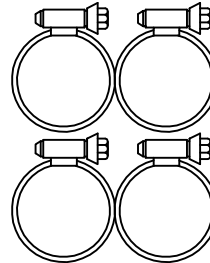

PHC1517 x 4

DESCRIPTION	QTY
AN970-3	4
MS21045-3	8
PW0084N	4
20mm 1/4 BUNDY TUBE	4
AN3-7A	2
AN960-10	4
AN3-12A	2
1/4 X 3/4 UNC CAPSCREW	4

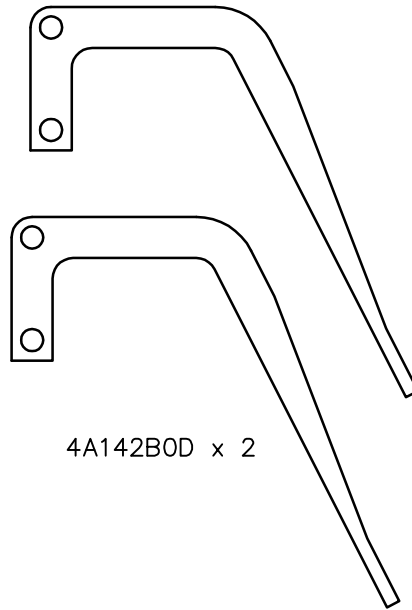

4A142B0D x 2

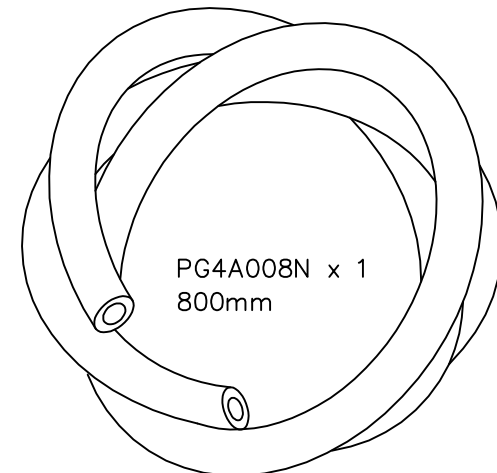

PG4A008N x 1
800mm

CARD J T 25-2: CABIN HEATER

DESCRIPTION	QTY
PX00394 Spring	1
4615074 right angle bracket	1
4A454CON	1
AN316-5R 5/16halfnuts unc	2
AN960-416	1
3/32 x 3/4 ROLL PIN	1
AN380-1-6 Split Pin	1
73-AS-4-3 RIVET	1
M4 PLAIN NUT	1
M4 NYLOC NUT	1
32250045/16threaded sleeve	1
3/16x1/2UNC CAP SCREW	4
M4 x 25 PAN SCREW	2
MS35214-26	2
4A454BOD	1

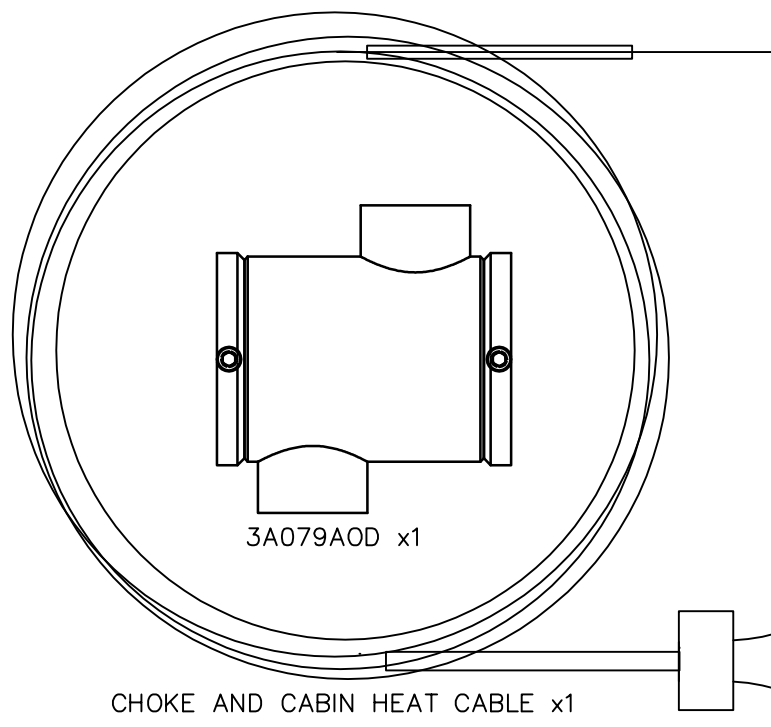

3A079AOD x1

CHOKE AND CABIN HEAT CABLE x1

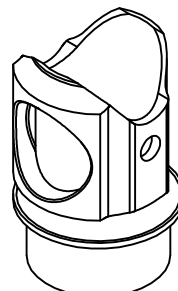

3A068BOD x1

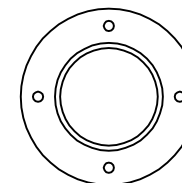

3240324 x 1

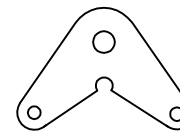

4028B94 x 1

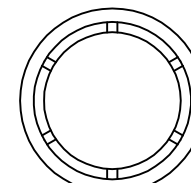

3A068FOD x1

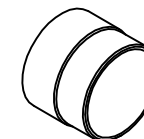

3A068EOD x 1

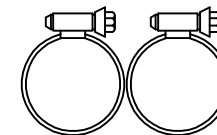
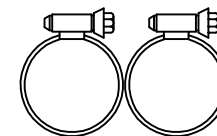

HOSE CLAMPS
18-38 x 4

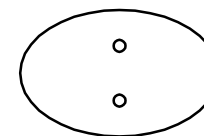

3A068COD x1

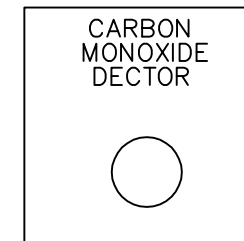

CARBON MONOXIDE
DETECTOR
CARBON DETECTOR x 1

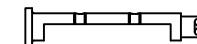

3A068DOD x1

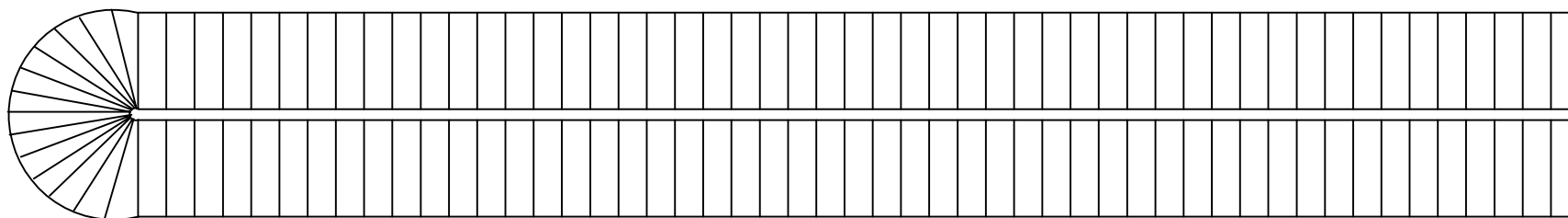

SCAT HOSE 1
1/4 x 1.5M