

## **Post-Paint>Fuselage>Engine>Fit Jabiru composite propeller and spinner**

### **Objectives of this task:**

In this task the propeller will be fitted to the engine and the spinner will be mounted. The propeller must be fitted before the engine can be rotated or run.

This task covers the fitting of either the Jabiru composite propeller only.

The cylinder compression can cause the propeller to move unexpectedly when rotating the engine and so for safety reasons all spark plugs should be removed and set aside and the spark plug holes should be covered with a clean cloth during this task.

### **Materials and equipment required:**

Spinner Hardware pack, Torque Seal inspection putty, small torque wrench

### **Fit the propeller**

1. Figure 1 shows typical propeller installation details.
2. Ensure that Propeller drive bushes – 6 off, are in place in the Crankshaft Propeller Flange (note that two are special, short parts and face “backwards” compared to the others – see Figure 2). Sand both sides of each spinner mounting plate flat in the flange/propeller mounting area. Fit the rear spinner backing plate to the flange.
3. When fitting a propeller turn the crank of the engine by hand until the magnets are aligned vertically and then fit the propeller with the blades close to horizontal. This method makes it likely that when the engine is turned off the propeller will naturally tend to come to rest with the blades close to horizontal. Note that this procedure does not apply to 3300 engines as they may stop in any position.
4. Fit propeller to flange.
5. Fit Propeller Bolts - 4 off. The bolts must be oriented with the nuts positioned furthest from the propeller flange (nuts forward for a standard tractor installation).
6. Fit front spinner plate and penny washers to front of propeller. Note the use of AN970 “Penny Washers” – this is required to distribute the load applied by the bolts.



7. Ensure that both spinner plates are locating correctly on the spigots of the propeller hub. The rear spinner plate is drilled to allow the rear hub bolt spigots to pass through and mate directly against the propeller flange. There must be nothing between these mating faces.
8. Progressively tighten bolts ensuring equal distribution of load and in a normal criss-cross torque sequence. Ensure that the hub is tightened evenly: check that the gap between the front and rear hub plates is the same on both sides of the propeller.
9. Using Torque Wrench, tighten propeller mounting bolts to the value given in Table 5.
10. Using Torque Wrench, tighten the outer blade clamp bolts to the value given in Table 5.

11. Check tracking of Propeller as detailed below.
12. Locate Spinner on Spinner Flange and fix with Machine Screws through tinnerman Washers.
13. Check Spinner tracking as detailed below in this section.
14. After the first 5 hours following the propeller installation or adjustment of the hub mounting bolts the spinner must be removed and the propeller bolts checked for correct tension per Table 5 in the propeller technical manual JPM0001-3.

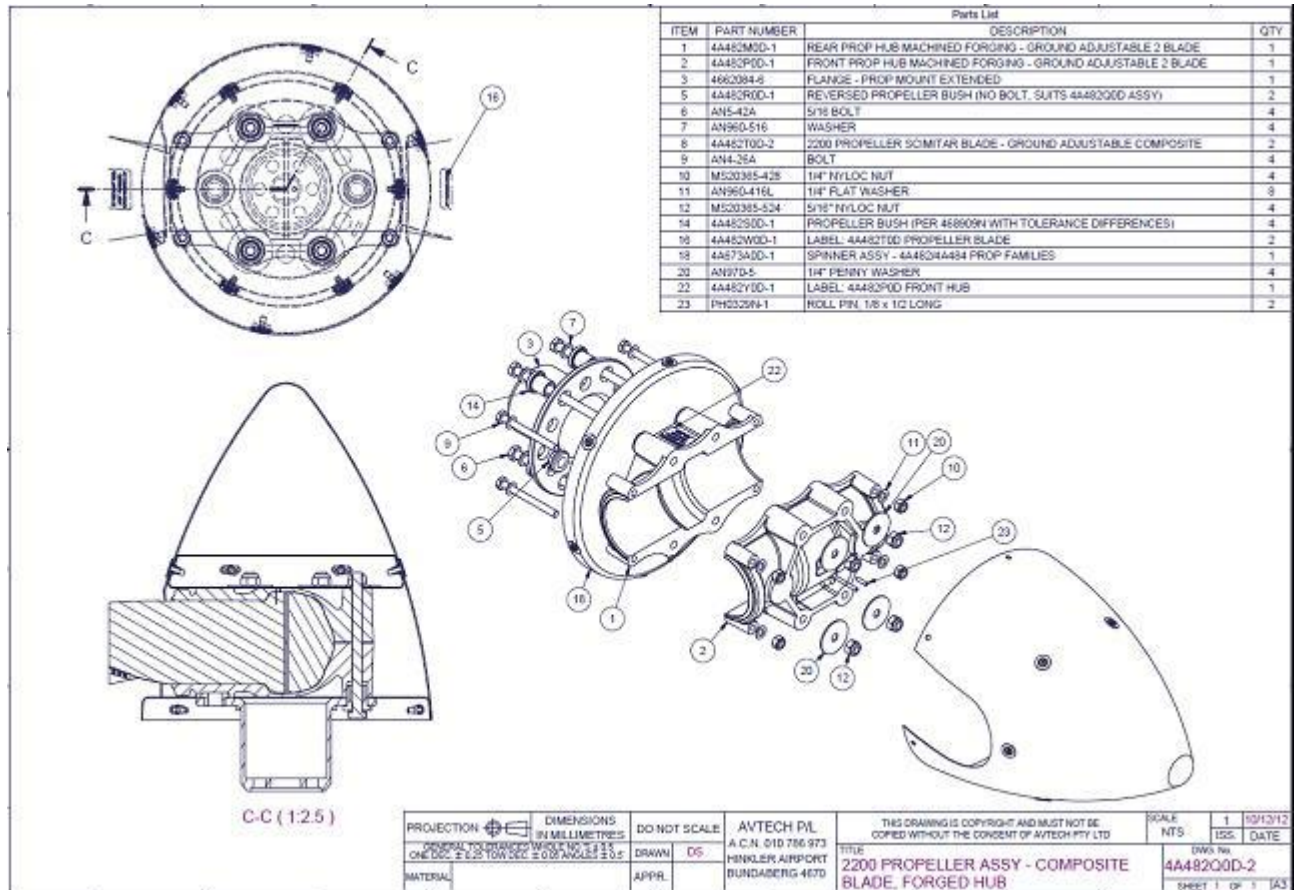

Figure 1 – Typical Propeller Installation

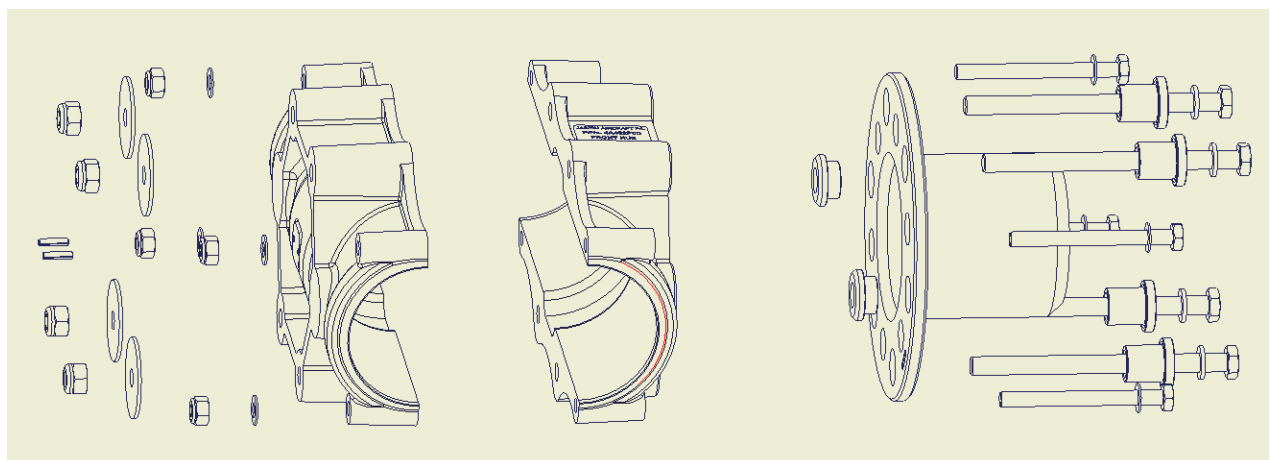

Figure 2 – Propeller Hub Assembly (Spinner and blades not shown)

**IMPORTANT**

*For all Jabiru Aircraft the spinner is an important and integral part of the propeller Assembly. It is essential to ensure adequate engine cooling. The aircraft must not be flown with the spinner removed.*

### **Procedure – Propeller Tracking**

1. Locate a fixed object on a flat floor so that it clears the Propeller tips by a small margin – 1-3mm.
2. Rotate the Propeller by hand.
3. Check that each blade clears the object by the same amount. Measure the clearance for each blade.
4. Maximum Tracking Error Tolerance is +/- 2mm.
5. If the Propeller is outside the approved tolerance, refer to JABIRU Aircraft Pty Ltd or a JABIRU Approved Service Centre for rectification instructions.

### **.Engine oil.**

At this time the engine should have oil of the recommended grade and quantity added – refer to the engine manual for specific detail. Pour slowly to minimize the chance of spillage and refit the dipstick. Remove the “Do Not Run: Contains No Oil” tag from the engine.

### **Pre-fit the spinner**

Test fit the spinner – it can be fitted in 2 positions, so try it each way and use the position where the holes all line up the best while giving an even gap around the base of the propeller.

When the mounting position has been decided, mark each component with a permanent marker as shown above so that if there is any need to remove the spinner or propeller all the parts can be refitted in the same position relative to each other.



Fit the spinner in place and line it up with the back of the rear mounting plate and then push a 5/32” pop rivet through all of the holes that line up. Working on one remaining hole at a time, drill a 5/32” hole through the spinner and the rear mounting plate and temporarily place a 5/32” pop rivet in each hole to keep the spinner and the mounting plate in alignment.

Work your way around all 6 holes in this manner. Repeat the process for the 6 holes in the front mounting plate. The spinner should resemble a porcupine at this stage, with pop rivets protruding from the 12 mounting holes. Remove the pop rivets and the spinner and drill all the holes in the spinner out to 3/16” to provide clearance for the screw threads.

Countersink each hole so that the Tinneman washers will sit flush against the spinner.



Fit the captive nuts to the inside of the spinner mounting plates - use the captive nut itself (a complete captive nut assembly is shown below left) as a jig (below right) to drill the rivet holes— thread the screw part way through the captive nut from the back and fit the exposed end of the thread into the hole, then drill the 2 x 3/32” rivet holes.



Countersink the rivet holes just enough to make a countersunk 3/32” rivet sit flush and fix the captive nuts in place and then enlarge the 5/32” holes in the mounting plates to 3/16” to provide clearance for the screw threads.

### ***Fit the spinner***

Fit the spinner using 5/32” countersunk screws and Tinneman washers.

Use a long sanding block to sand the rear mounting plate flush with the rear of the spinner.

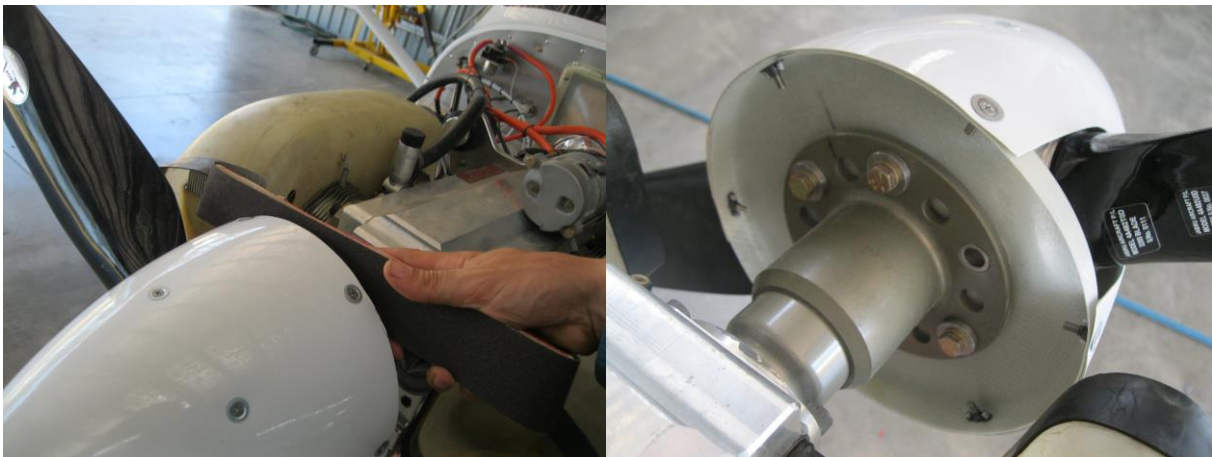

Refit the spark plugs – refer to the engine manual for the torque settings.

### ***Spinner Tracking***

1. Locate a fixed object on a flat floor to just clear the lower edge of the tip of the Spinner.
2. Rotate the propeller by hand and check that the Spinner runs true.
3. Correct any run-out by loosening machine screws, realigning spinner then retightening machine screws.

This completes the *Post-Paint>Fuselage>Engine>Fit Jabiru composite propeller and spinner* task.